

KATHMANDU UNIVERSITY  
End Semester Examination [C]  
April, 2023

Marks Scored:

Level : B.E.  
Year : IV

Course : MEPP 408  
Semester: I

Exam Roll No. :

Time: 30 mins.

F.M. : 20

Registration No.:

Date : 07 APR 2023

SECTION "A"

[20Q. × 1 = 20 marks]

Choose the most appropriate answer and **mark [X]** in the box.

1. The mean or average time between successive failures of a product is called \_\_\_\_\_.  
 Mean Time to Failure (MTTF)                       Mean Time between Failures (MTBF)  
 Mean Time to Repair (MTTR)                       Failure Rate (FR)
2. Which of the following statements regarding corrosion is **TRUE**?  
 Presence of impurities doesn't affect the rate of corrosion  
 Presence of electrolytes doesn't affect the rate of corrosion  
 Corrosion does not depend on the reactivity of the metal.  
 Strains in metals affect the rate of corrosion
3. Nip Points hazards in machines are \_\_\_\_\_.  
 hazards caused by multiple rotating parts present on machinery  
 occurring due projections present in machineries  
 hazards at the areas where employee holds or withdraws stocks by hand  
 hazards from fragments and projectiles
4. If the belt of an electric motor is broken, it needs \_\_\_\_\_.  
 Corrective Maintenance                       Scheduled Maintenance  
 Preventive Maintenance                       Condition Based Maintenance
5. How many rolling elements are present inside a hydrodynamic bearing?  
 10                       12                       15                       None of these
6. A leakage field during magnetic particle testing is weakest when a discontinuity interrupts the magnetic flux lines at an angle of \_\_\_\_\_.  
 60 degrees                       90 degrees                       45 degrees                       Zero degrees
7. Which of the following is not a cause of infant mortality failure?  
 Fatigue Failure                       Design failure  
 Installation failure                       Manufacturing errors
8. Which coupling would you suggest to use if the position of the shafts and the equipment cannot be changed for assembly or disassembly?  
 Gear Coupling                       Flanged Coupling  
 Split-muff Coupling                       Disk Coupling
9. Corrosion related to the velocity and flow of liquid is \_\_\_\_\_.  
 Erosion corrosion                       Pitting corrosion  
 Galvanic corrosion                       Corrosion Fatigue

10. Class E Fires can be extinguished by which type of extinguisher?  
 Water                     Carbon Dioxide    Wet Chemical    Oxygen
11. Which of the following is a condition monitoring technique?  
 Performance Analysis                     Failure Analysis  
 Root Cause Analysis                     Fault Tree Analysis
12. In liquid penetration testing, the role of the developer is to \_\_\_\_\_.  
 pull trapped penetrant out of defects    increase penetrant dwell time  
 help dye penetrate the defects well    clean the sample surface
13. Which of the following is the most relevant cause of wearing of belts bottom surfaces?  
 Idler malfunction                     Wear by guard  
 Misalignment of sheaves                     Worn Sheaves
14. Which of the following is **NOT** the function of lubricant in air compressors?  
 Wear reduction    Air Filtration    Heat Dissipation    Air Leak Prohibition
15. This form of corrosion occurs due to stagnant solutions in unexposed areas \_\_\_\_\_.  
 Pitting                     Cavitation                     Crevice                     Intergranular
16. With the increase in cost of preventive maintenance, the breakdown maintenance cost will \_\_\_\_\_.  
 decrease                     increase at a faster rate  
 not be affected                     maximize
17. Which of the following is **NOT** a requirement for LOTO devices?  
 Substantiality    Identifiable    Standardization    Inclusive
18. Which of the following is an advantage of Radiographic Testing?  
 Skilled technicians are available  
 Single exposure gives all the information on the sample  
 Technique is not limited by material type and density  
 Testing is not sensitive to change in thickness or voids
19. Which of the following couplings is **NOT** a flexible coupling?  
 Old Ham's Coupling                     Compression Coupling  
 Bushed Pin Type Coupling                     Universal Coupling
20. Objectives of planned Maintenance is \_\_\_\_\_  
 To involve and educate the operators in the functional concept, operation and maintenance of equipment by delegating the responsibility.  
 To secure health of operators and others by reducing the chances of accidents  
 To achieve good quality of goods and avoid scrap by keeping machines clean and maintaining their accuracy.  
 All of the above

Level : B.E.  
Year : IV  
Time : 2 hrs. 30 mins.

Course : MEPP 408  
Semester : I  
F. M. : 55

SECTION "B"

Attempt *ALL* questions.

1. You are the chief design engineer for a company that produces geared compressor manufactured as shown in the figure below. The company intends to minimize the failures of the geared compressors. So, the company CEO asked you to form a team of engineers and create a list of potential failures that can occur in the compressor.
  - a. Create a list of at least two major potential failure modes for each component of the geared compressor. [3]
  - b. Perform a quantitative Failure Mode and Effect Analysis to analyze the failure modes of the geared compressor. [4]
  - c. Determine the most critical failures based upon your analysis and recommend actions to reduce the most critical failures and reanalyze the failures. [3]

**Geared Compressor**

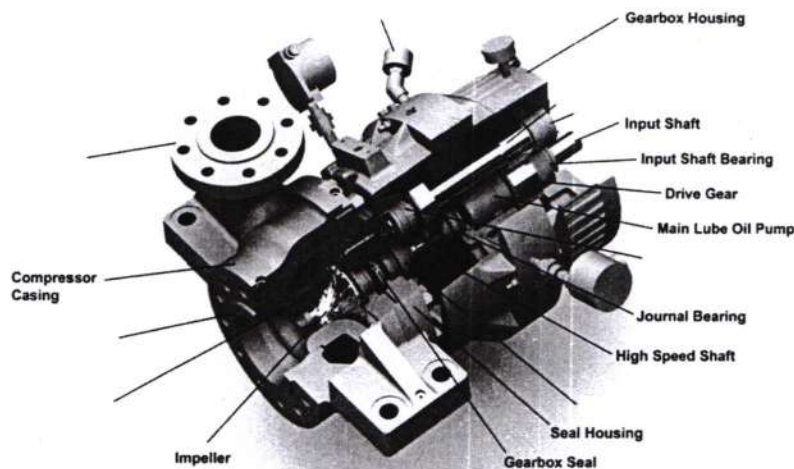

2. List and briefly explain the different types of Safeguards, Safety Devices and Safety Methods for protection from Machine Tool Hazards. [4]
3. What is Preventive Maintenance? Explain the different types of preventive maintenance. [1+3]
4. List down the basic components and parts of an electric motor. Construct a fault tree for the simple electric motor and perform a qualitative Fault Tree Analysis to determine the minimal cut sets of the motor failure using Boolean algebra and Minimal cut set theory. [2+5]
5. List the three elements of fire and briefly explain the three methods of extinguishing fires. [1.5+1.5]
6. List down the major functions of Computerized Maintenance Management System (CMMS) and briefly explain any three functions of CMMS. [2+3]

7. Explain the working principle and procedures of Eddy Current Testing in detail with the help of neat diagrams. [6]
8. Tabulate two major differences between Dry (Chemical) and Wet (Electrochemical) Corrosion. Briefly explain any four different types of corrosions. [2+4]
9. Write short notes on:
- a. Thermography [3]
  - b. Predictive Maintenance [3]
  - c. Procedures of Ultrasonic Testing [2]
  - d. Limitations of Radiographic Testing [2]