

KATHMANDU UNIVERSITY
End Semester Examination [C]
December, 2024

Marks Scored:

Level : B.E.

Year : III

Course : MEEG 318

Semester : II

Exam Roll No. :

Time: 30 mins.

F. M. : 10

Registration No.:

Date

19 DEC 2024

Data Books are not allowed for this multiple-choice exam. Necessary formulas are provided at the end of this paper.

SECTION "A"

[20 Q. × 0.5 = 10 marks]

Choose and encircle in the most appropriate option from each set of choices

- In a situation where multiple materials are eligible after screening, what is the first step in final material selection according to Ashby's methodology?
 Use of performance indices Cost analysis
 Risk analysis Prototyping and testing
- As a design engineer, which of the following is most critical when selecting a material for high-speed rotating machinery?
 Impact toughness Fatigue strength
 Modulus of elasticity Electrical conductivity
- Which manufacturing process is most effective for producing complex-shaped metal parts with high precision?
 Machining Forging
 Forming Casting
- Why is glass often used for the cover of LED light bulbs instead of plastic?
 Better insulation properties
 Greater energy efficiency
 Lower manufacturing cost
 Higher optical clarity and light transmission
- Two shafts will have equal strength, if _____
 diameter of both the shafts is same
 material of both the shafts is same
 twisting moment of both the shafts is same
 angle of twist of both the shafts is same
- A circular shaft can transmit a torque of 5 kN-m. If the torque is reduced to 4 kN-m, then the maximum value of bending moment that can be applied to the shaft is _____
 1 kN-m 3 kN-m 2 kN-m 4 kN-m

17. Efficiency of a worm drive _____
[] increases with lead angle
[] decreases with lead angle
[] first increases and then decreases with lead angle
[] lead angle has no effect
18. In case of spur gears the higher-pressure angle results in _____
[] narrow base and weaker teeth. [] Non-uniform motion transmission.
[] abrasion & pitting. [] wider base and stronger teeth.
19. For the same outer radius, ratio of power transmitting capacity of a cone clutch and single plate friction clutch is _____
[] more than one [] less or more depends of cone angle
[] less than one [] depends on coefficient of friction
20. Why do drum brakes typically require less frequent maintenance than disc brakes?
[] Used in lighter vehicles [] Higher heat dissipation
[] Made of more durable materials [] Self-energizing effect reduces wear

KATHMANDU UNIVERSITY
End Semester Examination [C]
December, 2024

Level : B.E.
Year : III
Time : 2 hrs. 30mins.

19 DEC 2024

Course : MEEG 318
Semester : II
F. M. : 40

SECTION "B"

[4 Q. × 10 = 40 marks]

Attempt ALL questions. Use of Data Book is ALLOWED for this examination. Assume and / or select suitable data if not specified.

1. (a) Pancbike, Nepal's oldest bicycle shop is planning to develop a brand-new model. They require a high strength, lightweight and precisely manufactured frame, with tolerances of 0.5 mm for a smooth, flawless ride. Additionally, the surface finish must be smooth, with a roughness of 0.5 μm , to ensure comfort and aesthetic appeal (**Refer Figure 1**).
 - I. Given an expected low production volume of around 500 units per year, choose the most appropriate manufacturing process for this bike frame component, focusing on achieving the desired tolerances and surface finish.
 - II. Would the selected manufacturing process be suitable for high-volume production (over 10,000 units per year)? Provide a brief explanation. [2+2=4]

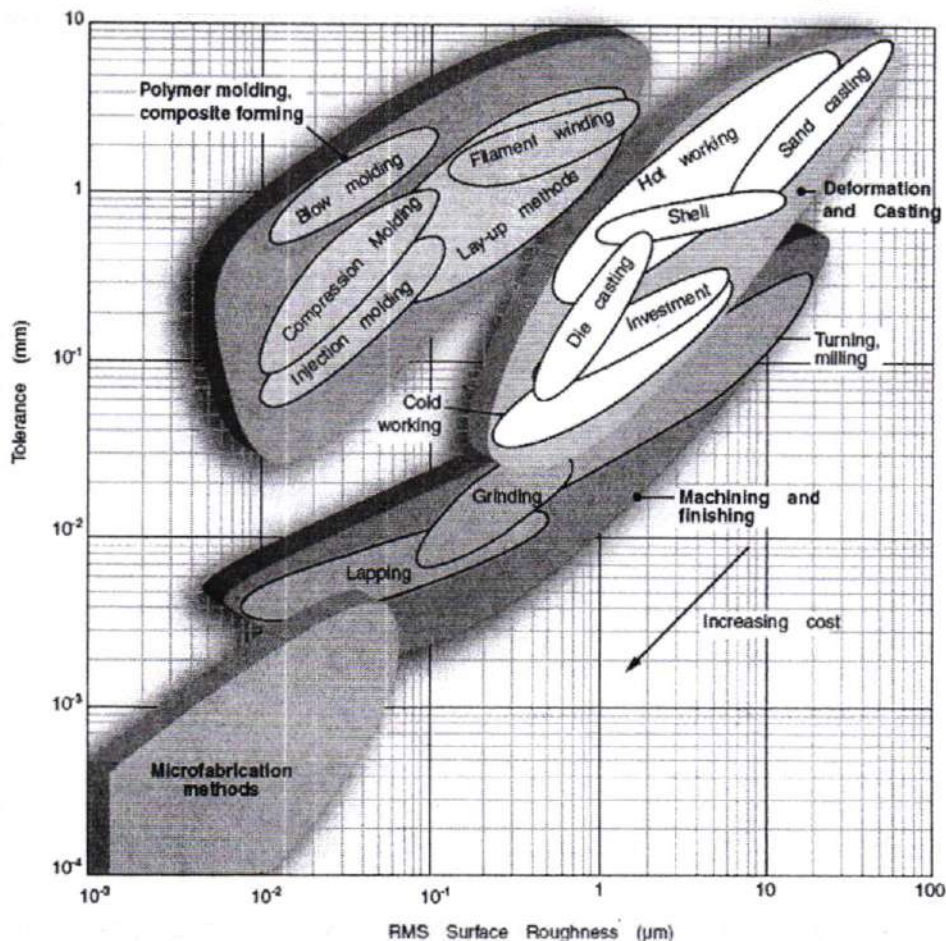

Figure 1: A plot of achievable tolerance versus surface roughness for assorted manufacturing operations. The dashed lines indicate cost factors; an increase in precision corresponding to the separation of two neighboring lines gives an increase in cost for a given process, or a factor of two.

- (b) A punching machine makes 30 working strokes per minute and is capable of punching 30 mm diameter holes in 20 mm thick **Cast Steel, Soft** plates. The punching operation takes place during $1/10$ th of a revolution of the crankshaft. Find the power required for the driving motor, assuming a mechanical efficiency of 85 %. Determine suitable dimensions for the rim cross-section of the flywheel, which revolves at 9 times the speed of crankshaft. The permissible coefficient of fluctuation of speed is 0.2. The flywheel is to be made of cast iron having a safe tensile stress of 6 MPa and density 7250 kg/m^3 . The diameter of the flywheel must not exceed 1.0 m owing to space restrictions. The hub and spokes may be assumed to provide 10 % of the rotational inertia of the wheel. Check for the centrifugal stress induced in the rim. [6]

2. (a) Himalayan Java is opening a new outlet at Kathmandu University, and they're on the quest for the perfect eco-friendly, reusable coffee mugs for their customers. But with such a diverse crowd, there's no single perfect answer. Three materials are considered: Stainless Steel, Double-Walled Plastic, and Ceramic.

- I. Analyze the strengths and weaknesses of each material in the context of a reusable coffee mug. Consider factors like durability, heat retention, weight, and cost.
- II. Based on your analysis, recommend the most suitable material for coffee mugs. Explain how this material best balances the needs of a wide-ranging audience, considering the factors mentioned above.
- III. What additional factors might influence Himalayan Java's final decision? Explain [2+2+2=6]

- (b) A multi-disc clutch has three discs on the driving shaft and two on the driven shaft. The inside diameter of the contact surface is 125 mm. The tentatively selected materials for the system are Woven asbestos against Steel, with the presence of lubricating fluid. Design the clutch for transmitting 20 kW at 500 rpm. Assume uniform wear condition. [1+1=2]

- (c) A differential band brake is shown in **Figure 2**. The width and the thickness of the steel band are 150 mm and 7 mm respectively and the maximum tensile stress in the band is 50 N/mm^2 . The coefficient of friction between the friction lining and brake drum is 0.15. Calculate the actuating force and the torque capacity of the brake. [1+1=2]

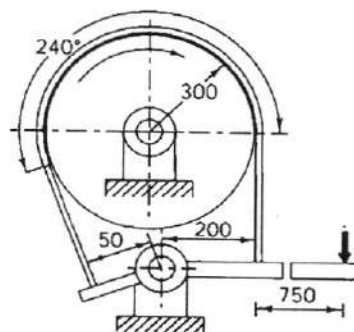

Figure 2 : A differential band brake. All dimensions are in mm,

3. (a) What are the different types of misalignment between two connected shafts? Explain briefly. [2]

(b) Practically, flexible couplings are used to connect the output shaft of an electric motor to the shaft of the centrifugal pump shaft to allow a slight misalignment. Take over a case that shafts are properly aligned (collinear) where a 3.0 kW electric motor with the rotational speed of 3000 revolutions per minute is used to drive a centrifugal pump with a muff coupling connecting the two shafts. **(Refer to the sample design in Figure 3).**

The starting torque of the motor is assumed to be 140 % of the rated torque. The shafts are subjected to torsional shear stress and Alloy Steel, 40 Cr 1 Mo 28, BHN 225 is selected as a shaft material with the factor of safety 2.0. The system uses the flat sunk keys to transmit the same torque as that of shaft which are also subjected to shear and compressive stresses. Based on stress conditions, Carbon Steel, C 55 Mn 75, is selected for the keys. The yield strength in compression is 125 % of the tensile strength in tension and yield shear strength is 57.7 % of yield tensile strength. The factor of safety for the keys is taken as 3.0. The sleeve is made of Grey Cast Iron, Malleable, S.A.E. 32510 and the factor of safety is 4.0 based on ultimate strength.

Design the shaft, key and muff coupling considering that the parts are subjected to torsional shear stress and direct-shear stress. Specify all required dimensions. Also, check whether the design is safe or not wherever necessary. Consider the effect of keyways while calculating the torsional shear stress induced in the coupling. [8]

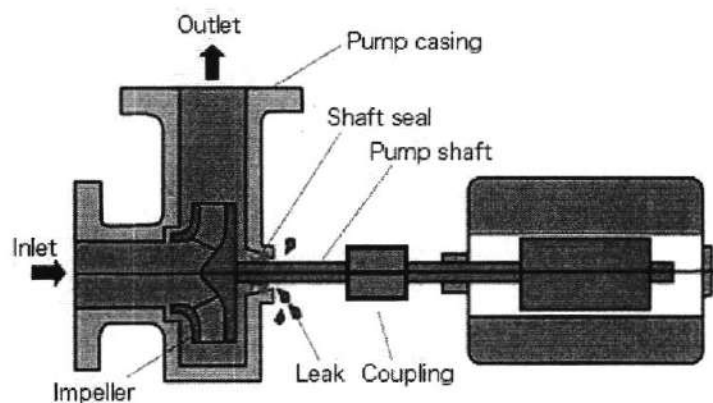

Figure 3: Connection of the pump shaft and electrical motor using a sleeve.

4. (a) What are the parameters causing dynamic loads on gear tooth? How are these considered in gear design? [2]

(b) A group of undergraduate mechanical engineering students from Kathmandu University is currently involved in the design process of a commercial tractor for efficient lawn mowing where one crucial aspect to consider is the wheel drive system. The team aims to implement a wheel drive system utilizing 20° full-depth involute profile Spur gears made of Silicon-manganese: S.A.E. 9260, oil quenched. The system consists of a 20 teeth pinion rotating at 700 rpm and a gear mounted on the wheel's hub rotating at speeds ranging from 300 to 400 rpm, with the engine delivering 14 kW to the gear pair. Due to space constraints, the larger gear diameter is limited to 320 mm and the face width of gear is 12.5 times that of module. Considering that the lawn tractor will be operational for 8 to 10 hours per day and subject to medium shocks. Design the gear and specify dimensions to assist the team as an expert in gear design and analysis. Assume that the velocity factor accounts for dynamic load.

[8]