

KATHMANDU UNIVERSITY
End Semester Examination
July/August, 2024

Level : B.E.
Year : III
Time : 2 hrs. 30mins.

30 JUL 2024

Course : MEEG 317
Semester : II
F. M. : 55

SECTION "B"

[5Q. × 11 = 55 marks]

Attempt ANY FIVE questions. Neat diagram must be drawn wherever necessary. Assume suitable data, if necessary.

1.
 - a. How does a spinneret contribute to the formation of fibers from a polymer solution or melt? [3]
 - b. Describe the thermoforming process. What are its applications? [4]
 - c. Discuss the critical factors that must be taken into account when designing components for plastic processing. [4]

2.
 - a. What do you mean by nontraditional methods of machining? What are their applications? [1+2=3]
 - b. Differentiate between Electron beam machining and electrochemical machining processes. [4]
 - c. Explain with neat sketches, principal, need, equipment, operation, advantages and disadvantages of the Plasma arc machining process. [4]

3.
 - a. Enumerate the various desirable properties of metallic powders use in powder metallurgy. [5]
 - b. A screen with a mesh count of 325 has wires with a diameter of 0.0035 mm. Determine:
i. the maximum particle size that can pass through the wire mesh.
ii. the percentage of open area in the screen. [3+3=6]

4.
 - a. List the important properties of a Bezier curve? [2]
 - b. A point P (-6,-4,-8) is rotated at 450 about x-axis and then it rotated at 600 about z-axis. Find the final coordinate of the point P. [4]
 - c. Generate a three dimensional Bezier curve using the following control points (5, 4, 2), (6, 2, 3), (5, -2, 4) and (6, -4, 3) [5]

5.
 - a. Define Flexible manufacturing system (FMS) and differentiate it with flexible manufacturing cell (FMC). [2]
 - b. What is group technology? How is group technology beneficial in increasing production? [2+3=5]

P.T.O.

- c. The square cup-shaped part is to be fabricated using stereolithography. The base of the cup is 40 mm on each side and is 5 mm thick. The walls are 4 mm thick, and the total height of the cup = 52 mm. The SL machine used for the job uses a spot diameter = 0.25 mm, and the beam is moved at a speed = 950 mm/s. Layer thickness = 0.10 mm. Repositioning and recoating time for each layer = 21s. Compute an estimate of the cycle time to build the part if the setup time = 20 min. [4]

6.

- a. What do you understand by word “canned cycle” in manual part programming? Explain with neat sketches the differences between the operation of the canned cycles G81 and G83. [3]
- b. Write a CNC Lathe part program for the following lathe work. [3]

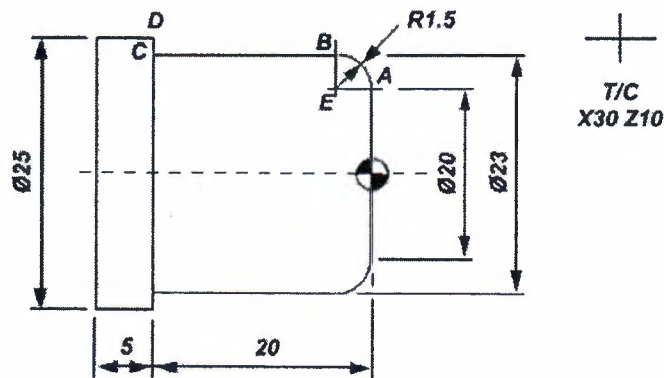

- c. Write a CNC Milling part program manuscript for the following figures. [5]
(Instruction: Use subroutine techniques and standard format)

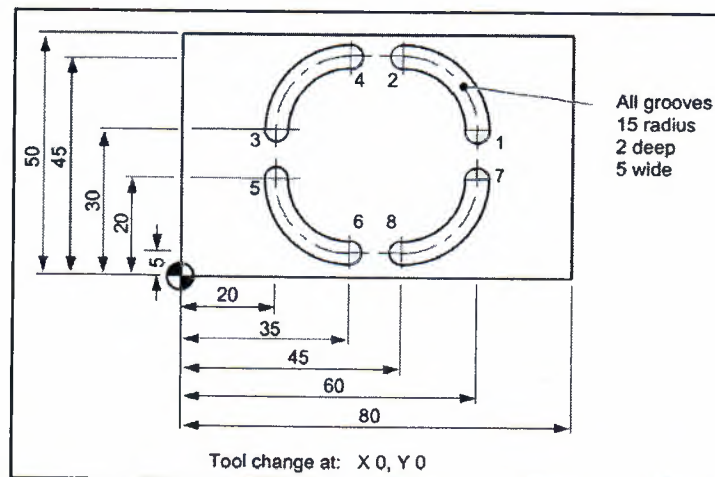

KATHMANDU UNIVERSITY
End Semester Examination
July/August, 2024

Marks Scored:

Level : B.E.
Year : III

30 JUL 2024

Course : MEEG 317
Semester : II

Exam Roll No. :

Time: 30 mins.

F. M. : 20

Registration No.:

Date :

SECTION "A"

[20 Q. × 1 = 20 marks]

Choose and mark [X] in the most appropriate option from each set of choices

- Identify the correct statement among the following:
 - Blending and mixing refer to the same process of combining different types of metal or alloy powders with different size distributions.
 - Blending involves mixing different metal or alloy powders with various size distributions, while mixing involves combining the same types of metal or alloy powders.
 - Blending involves mixing the same metal or alloy powders with different size distributions, while mixing involves combining different types of metal or alloy powders.
 - Blending and mixing refer to the same process of combining the same types of metal or alloy powders with different size distributions.
- To manufacture hollow components with thin sections, the following process is utilized:
 - Extrusion
 - Blow molding
 - Injection molding
 - Reaction molding
- Polyvinyl chloride is classified as:
 - A thermosetting plastic material
 - A thermoplastic material
 - An elastomeric material
 - An epoxy resin
- To fabricate complex parts using thermosetting materials, which of the following processes is employed:
 - Extrusion
 - Injection molding
 - Blow molding
 - Reaction injection molding
- During the atomization process, the size of metal powder particles is reduced by:
 - Decreasing the velocity of the gas
 - Reducing the volume of the gas
 - Reducing the pressure of the gas
 - Increasing the velocity of the gas
- To enhance the mechanical properties of a powder metallurgy component, which of the following finishing operations is employed?
 - Sizing
 - Coining
 - Repressing
 - Impregnation
- The green density of a powder metallurgy component will be increased by:
 - Increasing the sintering temperature
 - Decreasing the sintering temperature
 - Decreasing the compacting pressure
 - Increasing the compacting pressure
- Ultrasonic machining process is based on
 - Chemical machining
 - uniform pressure
 - uniform heating
 - wave vibrations of high frequency
- In electrochemical machining process, metal removal rate depends on
 - by sparking of the job
 - by shearing action of cutting tool
 - by dissolution of metal from the job
 - by bombardment of abrasive particles

10. What is a common characteristic of a transformation that results in a figure being rotated 180 degrees around a point?
- The figure is flipped over a line.
 - The figure's orientation is reversed.
 - The figure's size is altered proportionally.
 - The figure's position is shifted without changing its orientation.
11. The degree of a Bezier curve is a polynomial is _____ the number of control points utilized.
- equal to
 - one less than
 - two less than
 - two more than
12. In a coordinate plane, what is the result of reflecting a figure over the y-axis?
- The figure is shifted horizontally.
 - The y-coordinates of the figure's points are negated.
 - The x-coordinates of the figure's points are negated.
 - The x-coordinates and y-coordinates are both negated.
13. CNC lathe machines have built-in coordinate measuring systems. The zero position on the coordinate system is called
- Work Zero point
 - Programme zero point
 - Reference point
 - Machine Zero point
14. Numerical Control contouring is an example of
- absolute positioning
 - incremental positioning
 - continuous path positioning
 - point-to-point positioning
15. Numerical control (NC) _____
- is specific to milling machines
 - is a method for producing a precise number of parts per hour
 - is specific to lathe machines.
 - is a method for control using a set of instructions
16. Select the correct sequence for generating a prototype:
- STL file - 3D CAD data - CAD solid model - RP prototype
 - 3D CAD data - STL file - CAD solid model - RP prototype
 - CAD solid model - 3D CAD data - RP prototype - STL file
 - 3D CAD data - CAD solid model - STL file - RP prototype
17. A mid-range, moderate-volume operation is best classified as:
- line production
 - job shop production
 - batch production
 - mass production
18. Which system uses computers at lower-level strategies?
- Hybrid CAPP
 - Local CAPP
 - Variant CAPP
 - Generative
19. The type of layout generally preferred for low-volume production of non-standard products is:
- GT layout
 - Product layout
 - Process layout
 - Fixed position layout
20. The middle four digits of the OPTIZ classification method, are _____
- Form code
 - Secondary code
 - Stationary code
 - supplementary code