

KATHMANDU UNIVERSITY  
End Semester Examination [C]  
June/July 2024

Level : B.E.  
Year : III  
Time : 2 hrs. 30mins.

09 JUL 2024

Course : MEEG 301  
Semester : I  
F. M. : 55

SECTION "B"

[5Q × 11= 55 marks]

Attempt *ALL* questions. Assume suitable data if any is missing.

1.

- a. Define the phenomena of cavitation. [2]
- b. Explain the capillary effect and its causes. How is it affected by the contact angle? [2]
- c. Consider the flow of a fluid with viscosity  $\mu$  through a circular pipe. The velocity profile in the pipe is given as

$$u(r) = u_{max} \left( 1 - \frac{r^n}{R^n} \right)$$

Where  $u_{max}$  is the maximum flow velocity, which occurs at the centerline;  $r$  is the radial distance from the centerline; and  $u(r)$  is the flow velocity at any position  $r$ . Develop a relation for the drag force exerted on the pipe wall by the fluid in the flow direction per unit length of the pipe. [3]

- d. A steady, incompressible, two-dimensional velocity field is given by the following components in the  $xy$ -plane:

$$u = 1.85 + 2.33x + 0.656y$$

$$v = 0.754 - 2.18x - 2.33y$$

Calculate the acceleration field (find expressions for acceleration components  $a_x$  and  $a_y$ ) and calculate the acceleration at the point  $(x,y) = (-1,2)$  [4]

2.

- a. Explain why some people experience shortness of breath at high elevations. [1]
- b. The pressure difference between an oil pipe and water pipe is measured by a double-fluid manometer, as shown in figure below. For a given fluid heights and specific gravities, calculate the pressure difference  $\Delta P = P_B - P_A$  [5]

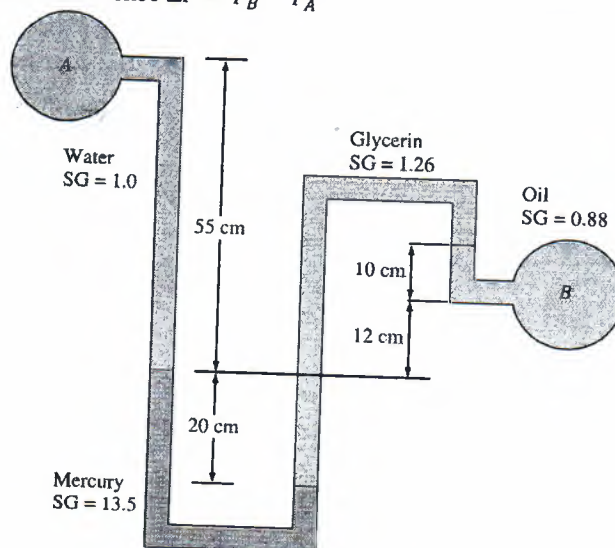

- c. A semicircular 40-ft-diameter tunnel is to be built under a 150-ft-deep, 800-ft-long lake, as shown in the figure below. Determine the total hydrostatic force acting on the roof of the tunnel. [5]

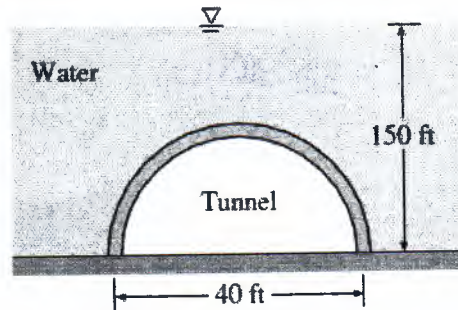

3.

- a. A 1.5 m high, 0.8 m diameter cylindrical water tank whose top is open to the atmosphere is initially filled with water. Now the discharge plug near the bottom of the tank is pulled out, and a water jet whose diameter is 2 cm streams out. The average velocity of the jet is approximated as  $V = \sqrt{2gh}$ , where  $h$  is the height of water in the tank measure from the center of the hole (a variable) and  $g$  is the gravitational acceleration. Determine how long it takes for the water level in the tank to drop to 0.5 m from the bottom. [6]

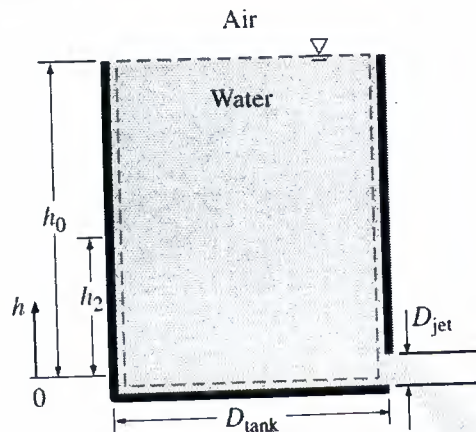

- b. Water is pumped from a lake to a storage tank 18 m above at a rate of 70 L/s while consuming 20.4 kW of electric power. Disregarding any frictional losses in the pipes and any changes in kinetic energy, determine (a) the overall efficiency of the pump-motor unit and b) the pressure difference between the inlet and the exit of the pump. [5]

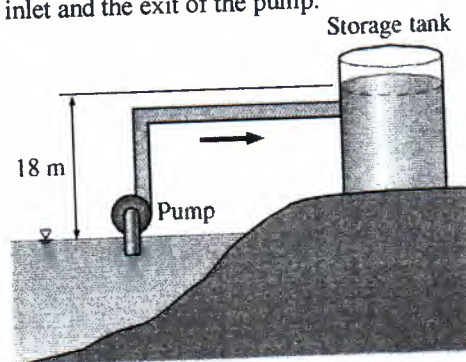

4.

- a. A horizontal pipe has an abrupt expansion from  $D_1=8$  cm to  $D_2=16$  cm. The water velocity in the smaller section is 10 m/s and the flow is turbulent. The pressure in the smaller section is  $P_1 = 410$  kPa. Taking the kinetic energy correction factor to be 1.06 at both the inlet and the outlet, determine the downstream pressure  $P_2$ , and estimate the error that would have occurred if Bernoulli's equation had been used. [6]

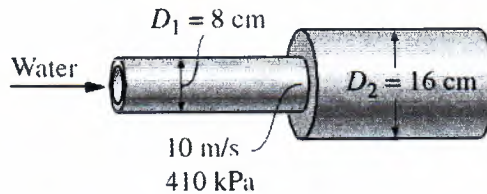

- b. The forming section of a plastics plant puts out a continuous sheet of plastic that is 1.2 m wide and 2 mm thick at a rate of 18 m/min. The sheet is subjected to airflow at a velocity of 4 m/s on both top and bottom surfaces normal to the direction of motion of the sheet. The width of the air cooling section is such that a fixed point on the plastic sheet passes through that section in 2 s. Using properties of air at 1 atm and  $60^\circ\text{C}$ , determine the drag force the air exerts on the plastic sheet in the direction of airflow. [5]

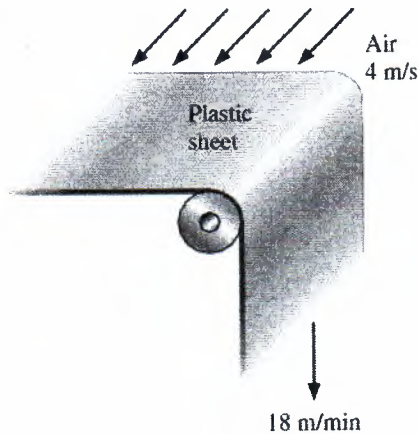

5.

- a. Air is flowing past a symmetrical airfoil at zero angle of attack. Is the (a) lift and (b) drag acting on the airfoil zero or nonzero? Explain. [3]
- b. What are different techniques for measurement of velocity and flow rate. Explain one of the techniques in detail. [3]
- c. Water at  $10^\circ\text{C}$  ( $\rho = 999.7$  kg/m<sup>3</sup> and  $\mu = 1.307 \times 10^{-3}$  kg/m.s) is flowing steadily in a 0.12 m diameter, 15 m long pipe at an average velocity of 0.9 m/s. Determine a) the pressure drop, b) the head loss, c) the pumping power requirement to overcome this pressure drop [5]



KATHMANDU UNIVERSITY  
End Semester Examination [C]  
June/July 2024

Marks Scored:

Level : B.E.

Year : III

Course : MEEG 301

Semester : I

Exam Roll No. :

Time: 30 mins.

F. M. : 20

Registration No.:

Date 09 JUL 2024

SECTION "A"

[20Q.  $\times$  1 = 20 marks]

**Choose and encircle in he most appropriate option**

1. The gage pressure in a pipe is measured by a manometer containing mercury ( $\rho = 13,600 \text{ kg/m}^3$ ). The top of the mercury is open to the atmosphere and the atmospheric pressure is 100 kPa. If the mercury column height is 24 cm, the gage pressure in the pipe is:  
a. 32 kPa      b. 24 kPa      c. 76 kPa      d. 68 kPa
2. Consider the vertical rectangular wall of a water tank with a width of 4 m and a height of 8 m. The other side of the wall is open to the atmosphere. The resultant hydrostatic force on this wall is:  
a. 1570 kN      b. 2380 kN      c. 2505 kN      d. 1254 kN
3. If the mechanical efficiency of a centrifugal pump is 68% and the manometric efficiency is 74%, what is the overall efficiency of the pump?  
a. 0.5032%      b. 50.32%      c. 83.2%      d. 0.832%
4. The velocity along the radial direction of the pipe,  $u(r)$  in the case of a hydrodynamically fully developed flow:  
a. Remains constant      b. Varies  
c. Depends on the location of the entrance region      d. Depends on the material
5. The pitot tube is used to measure  
a. Velocity at stagnation point      b. Stagnation pressure  
c. Static pressure      d. Dynamic pressure
6. During the measurement of the velocity of the flow, the difference in the water column height measurement by a piezometer and a pitot tube was found to be 10 cm. If the radius of the pipe was 2 cm, determine the velocity of the flow.  
a. 1.4 m/s      b. 1.6 m/s      c. 1.25 m/s      d. 1.8 m/s
7. A fluid particle is rotating at a speed of 12 rad/s. What is the vorticity of this particle?  
a. 12 rad/s      b. 24 rad/s      c. 48 rad/s      d. 6 rad/s
8. Which of the following parameter has the unit of force per unit length  
a. Dynamic viscosity      b. Kinematic viscosity  
c. Surface tension      d. Wall stress
9. A flow in which the viscosity of fluid is dominating over the inertia force is called  
a. Steady flow      b. Unsteady flow  
c. Laminar flow      d. Turbulent flow

10. An open tank contains 1 m deep water with 50 cm depth of oil of specific gravity 0.8 above it. The pressure at the bottom of the tank will be  
 a.  $4 \text{ kN/m}^2$                       b.  $10 \text{ kN/m}^2$                       c.  $12 \text{ kN/m}^2$                       d.  $14 \text{ kN/m}^2$
11. Stream lines and path lines always coincide in case of  
 a. Steady flow                      b. Laminar flow                      c. Uniform flow                      d. Turbulent flow
12. Equation of continuity is based on the principal of conservation of  
 a. Mass                      b. Energy                      c. Momentum                      d. None of the above
13. The major loss of energy in long pipes is due to  
 a. Sudden enlargement                      b. Sudden contraction  
 c. 90 degree bend                      d. Friction
14. In the case of an external parallel flow over a flat plat, which of the following drag can be neglected?  
 a. Pressure drag                      b. Friction drag                      c. Total drag                      d. Both drags are significant
15. With the same cross-sectional area and immersed in same turbulent flow, the largest total drag will be on  
 a. a circular disc of plate held normal to flow                      b. a sphere  
 c. a cylinder                      d. a streamlined body
16. For laminar flow in a pipe of circular cross section, the Darcy's friction factor  $f$  is  
 a. directly proportional to Reynolds number and independent of pipe wall roughness  
 b. directly proportional to pipe wall roughness and independent of Reynolds number  
 c. inversely proportional to Reynolds number and independent of pipe wall roughness  
 d. inversely proportional to pipe wall roughness and independent of Reynolds number
17. A tank of diameter 2 m consists of a hole at the bottom of diameter 0.1 m. The velocity at which the water exists the hole is 6 m/s. Determine the height of the water in the tank.  
 a. 1.83 m                      b. 2.22 m                      c. 3.04 m                      d. 4.33 m
18. The hydraulic grade line is  
 a. always above the centre line of pipe  
 b. never above the energy grade line  
 c. always sloping downward in the direction of flow  
 d. always above the energy grade line
19. In series-pipe problems  
 a. the head loss is same through each pipe  
 b. the discharge is same through each pipe  
 c. the discharge through each pipe is added to obtain total discharge  
 d. none of the above
20. In a hydropower plant, the difference between the free surfaces in the headrace and tailrace is 100 m. However, 15 m of head is lost due to the friction in the piping. If the water supplied to the turbine is at the rate of 160 kg/s, and the efficiency of the turbine is 82%, determine the shaft power output from the turbine.  
 a. 109 kW                      b. 113 kW  
 c. 118 kW                      d. 126 kW