

KATHMANDU UNIVERSITY
End Semester Examination [C]
April/May, 2023

Marks Scored:

Level : B.E.
Year : III

Course : MEEG 301
Semester : I

Exam Roll No. :

Time: 30 mins.

F. M. : 20

Registration N.:

Date : 30 APR 2023

SECTION "A"
[20Q. × 1 = 20 marks]

Encircle the most appropriate option.

- Stagnation point is the point in fluid mechanics where the velocity of the fluid at that point is _____.
a. Infinite b. Constant c. Maximum d. Zero
- Which of the following is a formula for the friction factor of circular pipes?
a. $Re/64$ b. $16/Re$ c. $64/Re$ d. $Re/16$
- If the mechanical efficiency of a centrifugal pump is 68% and the manometric efficiency is 74%, what is the overall efficiency of the pump?
a. 0.5032% b. 50.32% c. 83.2% d. 0.832%
- Rain drops are spherical because of _____.
a. Viscosity b. Air resistance
c. Surface tension forces d. Atmospheric pressure
- The pitot tube is used to measure _____.
a. Velocity at stagnation point b. Stagnation pressure
c. Static pressure d. Dynamic pressure
- The line action of the buoyant force acts through the Centroid of the _____.
a. Submerged body
b. Volume of the floating body
c. Volume of the fluid vertically above the body
d. Displaced volume of the fluid
- The imaginary line drawn in the fluid in such a way that the tangent to any point gives the direction of motion at that point, is known as _____.
a. Path line b. Stream line c. Streak line d. Potential line
- Which of the following parameter has the unit of force per unit length?
a. Dynamic viscosity b. Kinematic viscosity
c. Surface tension d. Wall stress
- A flow in which the viscosity of fluid is dominating over the inertia force is called _____.
a. Steady flow b. Unsteady flow c. Laminar flow d. Turbulent flow
- An open tank contains 1 m deep water with 50 cm depth of oil of specific gravity 0.8 above it. The pressure at the bottom of the tank will be _____.
a. 4 kN/m^2 b. 10 kN/m^2 c. 12 kN/m^2 d. 14 kN/m^2

11. Stream lines and path lines always coincide in case of _____.
a. Steady flow b. Laminar flow c. Uniform flow d. Turbulent flow
12. Equation of continuity is based on the principal of conservation of _____.
a. Mass b. Energy c. Momentum d. None of these
13. The major loss of energy in long pipes is due to _____.
a. Sudden enlargement b. Sudden contraction
c. 90 degree bend d. Friction
14. In the case of an external parallel flow over a flat plat, which of the following drag can be neglected?
a. Pressure drag b. Friction drag
c. Total drag d. Both drags are significant
15. With the same cross-sectional area and immersed in same turbulent flow, the largest total drag will be on a _____.
a. circular disc of plate held normal to flow
b. sphere
c. cylinder
d. streamlined body
16. For laminar flow in a pipe of circular cross section, the Darcy's friction factor f is _____.
a. directly proportional to Reynolds number and independent of pipe wall roughness
b. directly proportional to pipe wall roughness and independent of Reynolds number
c. inversely proportional to Reynolds number and independent of pipe wall roughness
d. inversely proportional to pipe wall roughness and independent of Reynolds number
17. The velocity distribution for laminar flow through a circular tube in the fully developed region _____.
a. is constant over the cross-section
b. varies linearly from zero at walls to maximum at centre
c. varies parabolically with maximum at the centre
d. depends on the entrance length
18. The hydraulic grade line is _____.
a. always above the centre line of pipe
b. never above the energy grade line
c. always sloping downward in the direction of flow
d. always above the energy grade line
19. In series-pipe problems _____.
a. the head loss is same through each pipe
b. the discharge is same through each pipe
c. the discharge through each pipe is added to obtain total discharge
d. none of the above
20. Bernoullis equation deals with the law of conservation of _____.
a. mass b. momentum c. energy d. work

SECTION "B"

[5Q × 11 = 55 marks]

Attempt ALL questions. Assume suitable data if any is missing

1. a. Define Viscous and Inviscid regions of the flow. [2]
- b. Given the Eulerian velocity vector field

$$V = 3t \cdot i + xz \cdot j + ty^2 \cdot k$$
 Find the total acceleration of a particle. [4]
- c. Two water tanks are connected to each other through a mercury manometer with inclined tubes, as shown in Figure 1. If the pressure difference between the two tanks is 20 kPa, calculate a and θ . [5]

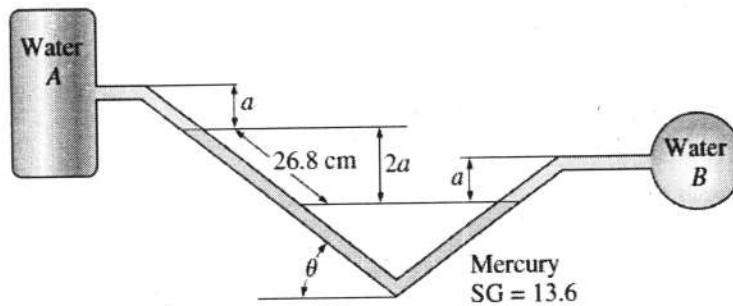

Figure 1

2. a. Explain hydrodynamically fully developed region in a pipe using figure and mathematical relation. [4]
- b. A 1.5 m high, 0.8 m diameter cylindrical water tank whose top is open to the atmosphere is initially filled with water. Now the discharge plug near the bottom of the tank is pulled out, and a water jet whose diameter is 2 cm streams out. The average velocity of the jet is approximated as $V = \sqrt{2gh}$, where h is the height of water in the tank measure from the center of the hole (a variable) and g is the gravitational acceleration. Determine how long it takes for the water level in the tank to drop to 0.5 m from the bottom. [7]

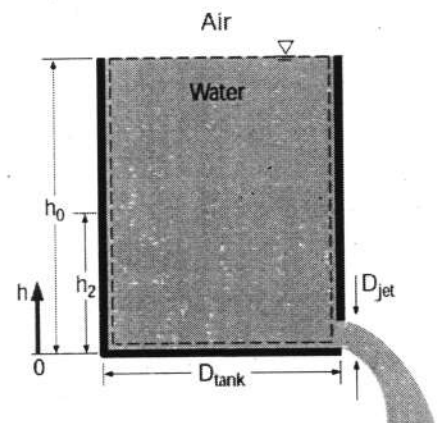

Figure 2

3. a. A wind tunnel draws atmospheric air at 20 °C and 101.3 kPa by a large fan located near the exit of the tunnel. If the air velocity in the tunnel is 3 m/s, determine the pressure in the tunnel. [5]

- b. An oil pump is drawing 25 kW of electric power while pumping oil with $\rho = 860 \text{ kg/m}^3$ at a rate of $0.1 \text{ m}^3/\text{s}$. The inlet and outlet diameters of the pipe are 8 cm and 12 cm, respectively. If the pressure rise of oil in the pump is measured to be 250 kPa and the motor efficiency is 90 percent, determine the mechanical efficiency of the pump. Take the kinetic energy correction factor to be 1.05. [6]

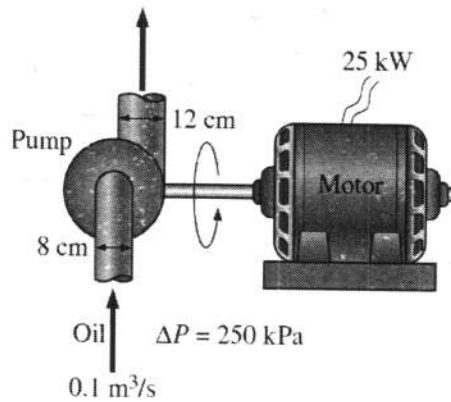

Figure 2

4. a. Water at 10°C ($\rho = 999.7 \text{ kg/m}^3$ and $\mu = 1.307 \times 10^{-3} \text{ kg/m}\cdot\text{s}$) is flowing steadily in a 0.12 cm diameter, 15 m long pipe at an average velocity of 0.9 m/s. [5]
Determine i) the pressure drop, ii) the head loss, iii) the pumping power requirement to overcome this pressure drop.
- b. The top surface of the passenger car of a train moving at a velocity of 95 km/h is 2.1 m wide and 8 m long. If the outdoor air is at 1 atm and 25°C , determine the drag force acting on the top surface of the car. [6]

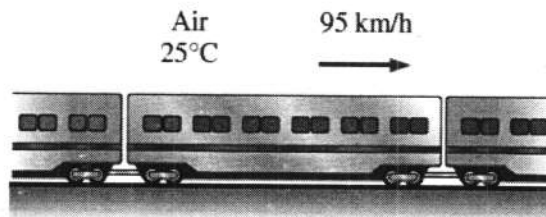

Figure 3

5. a. What are different techniques for measurement of velocity and flow rate? Explain three of the techniques in detail. [5]
- b. Water at 15°C is drained from a large reservoir using two horizontal plastic pipes connected in series. The first pipe is 20 m long and has a 10 cm diameter, while the second pipe is 35 m long and has a 4 cm diameter. The water level in the reservoir is 18 m above the centerline of the pipe. The pipe entrance is sharp-edged and the contraction between the two pipes is sudden. Neglecting the effect of the energy correction factor, determine the discharge rate of water from the reservoir. [6]

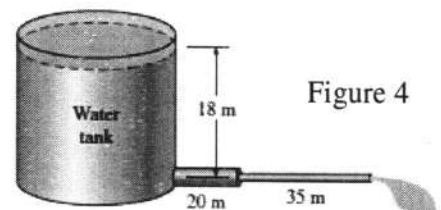
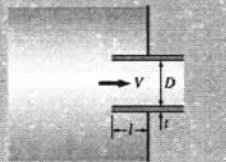
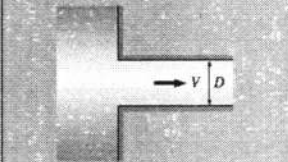
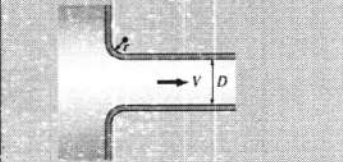
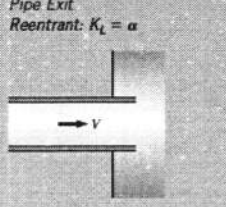
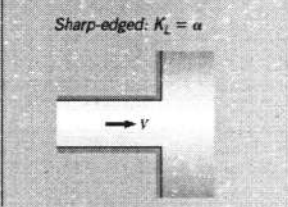
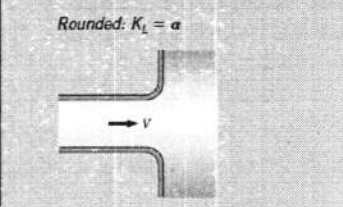

Figure 4

Some relevant formula and datasheet:

$$\frac{1}{\sqrt{f}} = -2.0 \log \left(\frac{\epsilon/D}{3.7} + \frac{2.51}{\text{Re} \sqrt{f}} \right) \quad (\text{turbulent flow})$$

Loss coefficients K_L of various pipe components for turbulent flow (for use in the relation $h_L = K_L V^2 / 2g$, where V is the average velocity in the pipe that contains the component)

<p>Pipe Inlet Reentrant: $K_L = 0.80$ ($l \ll D$ and $l \approx 0.1D$)</p> 	<p>Sharp-edged: $K_L = 0.50$</p> 	<p>Well-rounded ($r/D > 0.2$): $K_L = 0.03$ Slightly rounded ($r/D = 0.1$): $K_L = 0.12$ (see Fig. 8-39)</p> 
<p>Pipe Exit Reentrant: $K_L = \alpha$</p> 	<p>Sharp-edged: $K_L = \alpha$</p> 	<p>Rounded: $K_L = \alpha$</p> 

Note: The kinetic energy correction factor is $\alpha = 2$ for fully developed laminar flow, and $\alpha = 1.05$ for fully developed turbulent flow.

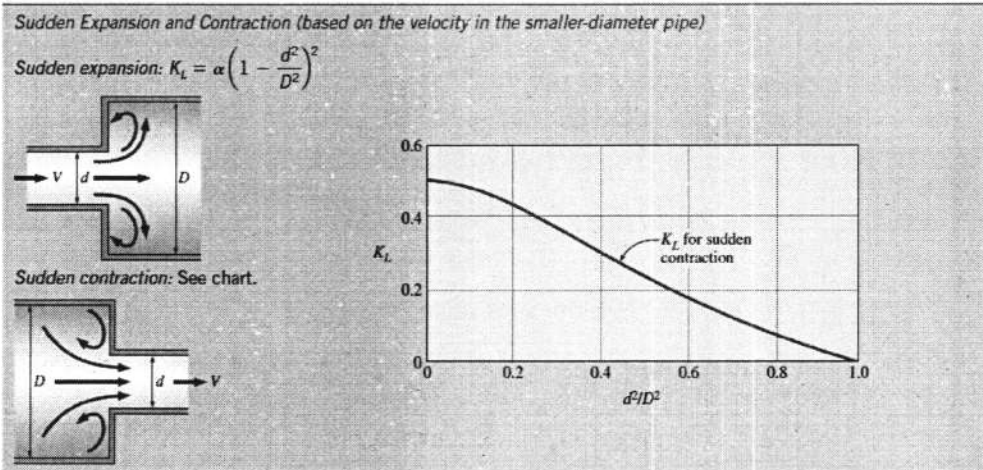

Laminar: $C_f = \frac{1.33}{\text{Re}_L^{1/2}} \quad \text{Re}_L \leq 5 \times 10^5$

Turbulent: $C_f = \frac{0.074}{\text{Re}_L^{1/5}} \quad 5 \times 10^5 \leq \text{Re}_L \leq 10^7$

$$C_f = \frac{0.074}{\text{Re}_L^{1/5}} - \frac{1742}{\text{Re}_L} \quad 5 \times 10^5 \leq \text{Re}_L \leq 10^7$$

