

KATHMANDU UNIVERSITY
End Semester Examination
July/August 2024

Level : B.E.
Year : II
Time : 2 hrs. 30mins.

17 AUG 2024

Course : MEEG 216
Semester : I
F. M. : 55

SECTION "B"
[55 marks]

Attempt *ALL* questions. Assume the value of acceleration due to gravity (g) = 9.8 m/sec^2 wherever it is required to use.

1. Determine an equivalent force couple system at point A and point B. Consider the weight of the block 30 kN acting midpoint of OE. [4]

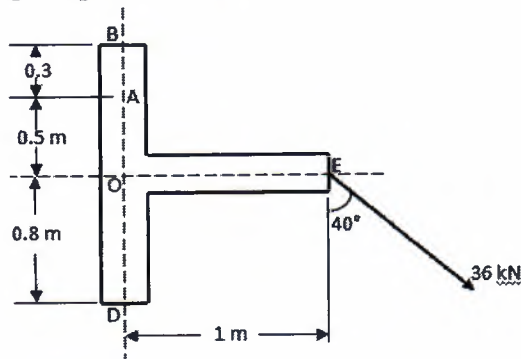

2. Compute the force in members BD, BC and AC of the loaded cantilever truss as shown in the figure below. [5]

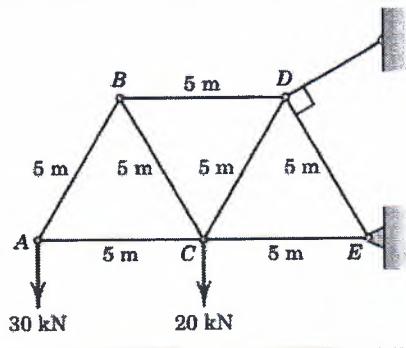

3. Determine the moment of inertia of the plane area shown in the figure below about its centroidal axis. Also find the moment of inertia about the axis parallel to the centroidal axis and passing through the point at a distance of 6 cm from the base of the plane area. [8]

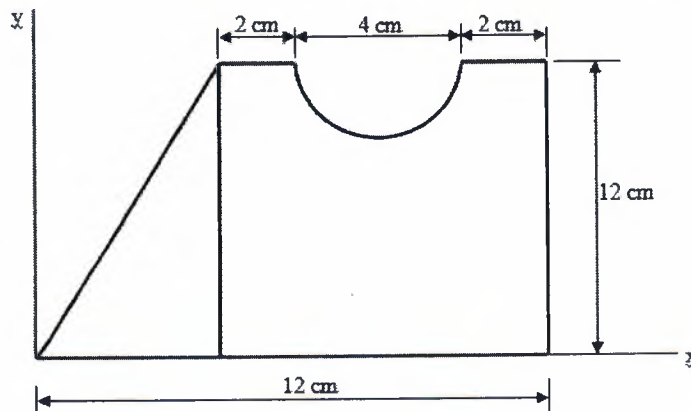

P.T.O.

4. A bullet is fired making angle 30 degrees to the horizontal from a hill which strikes the target which is 80 m lower than the horizontal passing through the firing point. The initial bullet velocity is 100 m/sec. Find the following: [6]
- The maximum height above horizontal to which the bullet will rise and its velocity at that point
 - The velocity of bullet when it strikes the target
 - The total time required for the bullet when it strikes the target.
5. A block of mass 10 kg is placed on an inclined plane that makes an angle of 30 degrees with the horizontal. The coefficient of static and kinetic friction between the block and the plane is 0.6 and 0.4 respectively. A force P is applied horizontally to the block. Determine the range of values for the force P that will keep the block at rest on the inclined plane. Also calculate the frictional force acting on the block when i) P = 50 N and ii) P = 150 N. Also state the position of the block in both cases. [6]
6. A particle 'P' is moving along a straight line with its initial velocity 3 m/sec when started from point 'A' and with acceleration of 1.5 m/sec². Another particle 'Q' starts from the same point 'A' with velocity of 11.4 m/sec and acceleration of 1.2 m/sec², 3 seconds after 'P' has left the point 'A' [7].
- Determine the distance from point 'A' when 'Q' will overtake 'P'.
 - Further show that once 'Q' will overtake 'P', 'Q' will never be ahead of 'P' by more than 9.6 m.
7. Two weights W_1 and W_2 are connected by a weightless string which passes over a smooth pulley. The weight W_1 is resting on an inclined plane which makes an angle θ degree with horizontal and another weight W_2 hangs vertically downward. Derive the expression for calculating acceleration of the system and tension in the string. Take coefficient of friction between the contact surfaces as μ .
If $W_1 = 10$ N, $W_2 = 50$ N, $\theta = 20$ degree and $\mu = 0.2$, find the acceleration of the system, tension in the string and distance moved by the body in 3 seconds starting from rest. [7]
8. A cycle is travelling along a straight road with a velocity of 10 m/sec. Determine the velocity of point A on the front wheel as shown in the figure below. Radius of cycle wheel = 400 mm and A is midpoint of the radius. [4]

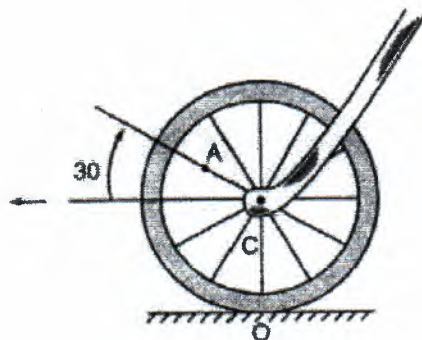

9. Two men of mass 60 kg and 90 kg dive off from the end of a boat of mass 40 kg so that their relative velocity with respect to the boat is 8 m/sec. If the boat is initially at rest determine its final velocity for the following conditions: [8]
- a. If two men dive simultaneously
 - b. The 60 kg man dives first followed by 90 kg man
 - c. The 90 kg man dives first followed by 60 kg man.

KATHMANDU UNIVERSITY
End Semester Examination
July/August 2024

Marks Scored:

Level : B.E.

Year : II

Exam Roll No. :

Time: 30 mins.

Registration No.:

Course : MEEG 216

Semester : I

F. M. : 20

Date : 11 AUG 2024

SECTION "A"

[20Q. × 1 = 20 marks]

Choose the most appropriate answer and mark [X]. Assume the value of acceleration due to gravity (g) = 9.8 m/sec^2 wherever it is required to use.

1. A body is in equilibrium under the action of three forces. These forces must be
 Concurrent and Coplanar Parallel and coplanar
 Concurrent and non-coplanar Parallel and non coplanar
2. The sum of two forces acting at a point is 16 N. If the resultant force is 8 N and its direction is perpendicular to the minimum force, then the forces are
 6 N and 10 N 8 N and 8 N 4 N and 12 N 2 N and 14 N
3. Which of the following condition doesn't affect the magnitude of the moment?
 If the point of application of force is opposing the line of action
 If the point of application of force is along the line of action
 If the moment of centre is shifted along a line perpendicular to the line of action
 If the resultant of the forces changes
4. We often use the centre of mass of the composite area to calculate the moment of inertia. The centre of mass for these composite bodies is in the ratio of
 The product of centroid and mass to the total weight
 The addition of centroid and mass to the total weight
 The product of centroid and mass to the total mass
 The addition of centroid and mass to the total mass
5. The centroid of the triangular lamina with vertices at (0, 0), (4, 0) and (0, 3) is
 (2, 1.5) (1, 1) (4/3, 1) (4/3, 1/3)
6. What role does the centroid play in the calculation of moments of inertia?
 It is used as the axis of rotation
 It determines the distribution of mass about the axis
 It helps simplify the calculation by reducing it to a single point
 It is not relevant to moments of inertia
7. The coefficient of friction is defined as the ratio of
 Normal force to frictional force Frictional force to normal force
 Frictional force to applied force Applied force to normal force

19. A stone falls from the top of a building 200 m high and at the same time another is projected vertically upwards with a velocity of 50 m/sec, then the two will meet
 After 1 sec After 2 sec After 4 sec After 5 sec
20. Three forces acting on a rigid body are represented in magnitude, direction and line of action by the three sides of a triangle taken in order. The forces are equivalent to a couple whose moment is equal to
 Area of the triangle Twice the area of the triangle
 Half the area of triangle One third the area of the triangle

