

KATHMANDU UNIVERSITY
End Semester Examination [C]
December, 2018

Marks Scored:

Level : B.E.

Year : II

Course : MEEG 206

Semester: II

Exam Roll No. :

Time: 30 mins.

F.M. : 20

Registration No. :

Date DEC 30 2018

SECTION A

[20 Q.×1=20 marks]

Encircle the most appropriate answer.

1. Shaft revolving in a bearing is a
 - a. Rolling pair
 - b. Sliding pair
 - c. Higher pair
 - d. Lower pair
2. A combination of kinematic pairs, joined in such a way that relative motion between them is completely constrained, is called
 - a. Mechanism
 - b. Kinematic chain
 - c. Structure
 - d. Inversion
3. It is required to connect two parallel shafts, the distance between whose axes is small and variable. The shaft are coupled by
 - a. Universal coupling
 - b. Oldham coupling
 - c. Flexible coupling
 - d. Knuckle joint
4. Whitworth quick return mechanism is obtained by inversion of
 - a. Kinematic chain
 - b. Five link mechanism
 - c. Slider crank mechanism
 - d. Roller cam mechanism
5. According to Kennedy's theorem, if three bodies have plane motions, their instantaneous centre lies in a
 - a. Triangle
 - b. Point
 - c. Straight line
 - d. Two lines
6. Slip in belt drive is due to
 - a. Material of pulley
 - b. Size of pulley
 - c. Uneven extension and contraction due to varying tension
 - d. Insufficient friction between pulley and belt
7. The centrifugal tension in belts
 - a. Increases power transmitted
 - b. Decreases power transmitted
 - c. Have no effect on the power transmitted
 - d. Increases power transmitted up to a certain speed and then decreases
8. In a gear having involute teeth, the normal to the involute is a tangent to the
 - a. Pitch circle
 - b. Base circle
 - c. Addendum circle
 - d. Dedendum circle
9. Fundamental Law of gearing is satisfied if
 - a. two surfaces slide smoothly
 - b. common normal at the point of contact passes through the pitch point on the line joining the centers of rotation
 - c. number of teeth = P.C.D. / module
 - d. addendum is greater than dedendum

10. Calculate speed of driving shaft in compound gear train, if the drivers have 50, 60, 80 and 100 teeth and followers have 18, 40, 60 and 80 teeth. Speed of driven shaft is 150 rpm
 a. 21.73 rpm b. 30.23 rpm c. 19.77 rpm d. 25.45 rpm
11. What is meant by node point?
 a. The point at which amplitude of vibration is maximum
 b. The point at which amplitude of vibration is minimum
 c. The point at which amplitude of vibration is zero
 d. The point at which the amplitude is negative
12. In Involute gears, the pressure angle is
 a. Dependent on the size of teeth b. Dependent on the number of teeth
 c. Always constant d. Always variable
13. Length of arc of contact is given by
 a. Arc of approach – Arc of recess b. Arc of approach + Arc of recess
 c. Arc of approach / Arc of recess d. Arc of approach \times Arc of recess
14. An open belt running over two pulleys 240 mm and 600 mm diameter connects Two parallel shafts 3 meters apart, the length of the belt required is,
 a. 3.840m b. 6.35m c. 7.33m d. 8.21m
15. For low and moderate speed engine, the cam follower should move with
 a. uniform velocity b. simple harmonic motion
 c. uniform acceleration and retardation d. cycloidal motion
16. In its simplest form, cam mechanism consists of following number of links.
 a. 1 b. 2 c. 3 d. 4
17. Determine natural frequency of a system, which has equivalent spring stiffness of 30000N/m and mass of 20 kg?
 a. 12.32Hz b. 4.10Hz c. 6.16Hz d. 8.20Hz
18. Shaft carrying three rotors will have
 a. One node b. Two node c. Three node d. No node
19. A rotor supported at A and B carries two masses as shown in the below figure. The rotor is
 a. dynamically balanced
 b. statically balanced
 c. statically and dynamically balanced
 d. not balance
20. Which gear train is used for higher velocity ratios in a small space?
 a. Simple gear train b. Compound gear train
 c. Reverted gear train d. Epicyclic gear train

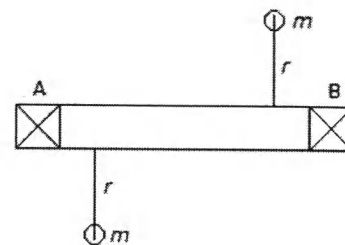

Level : B.E.
Year : II
Time : 2 hrs. 30 mins.

Course : MEEG 206
Semester: II
F.M. : 55

SECTION "B"

Attempt *ALL* questions. Assume any missing data with proper reason.

1.
 - a. What is degree of freedom and what does it indicate? [1+1]
 - b. Locate all the instantaneous centers of the slider crank mechanism as shown in the figure. The lengths of crank OB and connecting rod AB are 100 mm and 400 mm respectively. If the crank rotates clockwise with an angular velocity of 10 rad/s, find: Velocity of the slider A and Angular velocity of the connecting rod AB. [2+3]

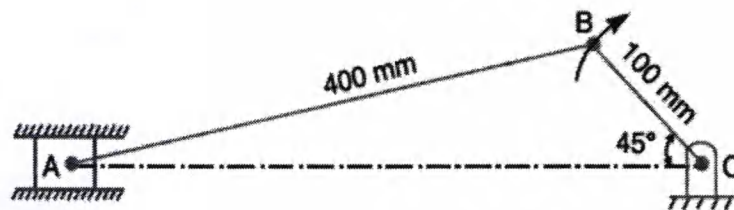

2.
 - a. Explain working mechanism of Geneva mechanism with appropriate figure. [2]
 - b. A sketch of a front loader is shown in Figure below. Draw a kinematic diagram of the mechanism. Specify the number of links, number of joints and calculate the mobility for the mechanism. [3+3]

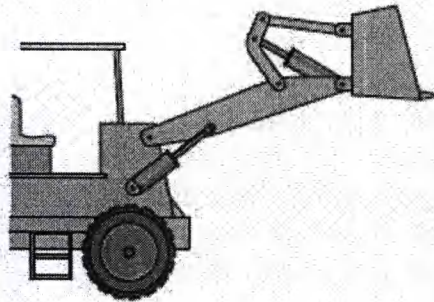

3. State principal of kinematic inversion in context of cam design. A cam is to be designed for a knife edge follower with the following data :
 - Cam lift = 40 mm during 90° of cam rotation with simple harmonic motion.
 - Dwell for the next 30°.
 - During the next 60° of cam rotation, the follower returns to its original position with simple harmonic motion.
 - Dwell during the remaining 180°.Draw the displacement diagram and profile of the cam when the line of stroke of the follower passes through the axis of the cam shaft. The radius of the base circle of the cam is 40 mm. [8]

4. State the meshing condition for involute gears. A pinion having 18 teeth engages with an internal gear having 72 teeth. If the gears have involute profiled teeth with 20° pressure angle, module of 4 mm and the addenda on pinion and gear are 8.5 mm and 3.5 mm respectively, find the length of path of contact. [2+6]
5. Two shafts A and B are co-axial. A gear C (50 teeth) is rigidly mounted on shaft A. A compound gear D-E gears with C and an internal gear G. D has 20 teeth and gears with C and E has 35 teeth and gears with an internal gear G. The gear G is fixed and is concentric with the shaft axis. The compound gear D-E is mounted on a pin which projects from an arm keyed to the shaft B. Find the number of teeth on internal gear G assuming that all gears have the same module. If the shaft A rotates at 110 r.p.m., find the speed of shaft B. [6]

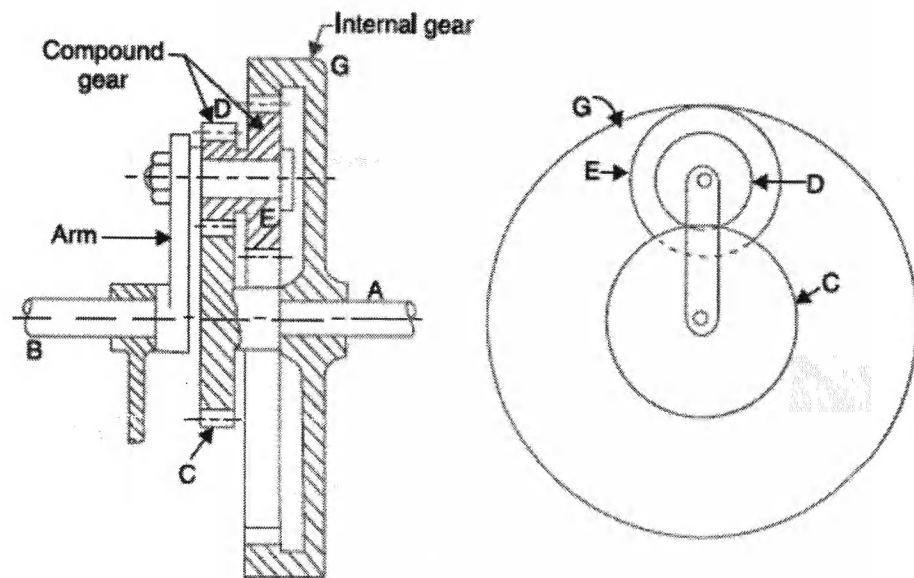

6. a. Two pulleys, one 450 mm diameter and the other 200 mm diameter are on parallel shafts 1.95 m apart and are connected by a crossed belt. Find the length of the belt required and the angle of contact between the belt and each pulley. What power can be transmitted by the belt when the larger pulley rotates at 200 rev/min, if the maximum permissible tension in the belt is 1 kN, and the coefficient of friction between the belt and pulley is 0.25? [6]
- b. What is the difference between gear train and rope drive in terms of their applications? [2]
7. A shaft of 100 mm diameter and 1 meter long has one of its end fixed and the other end carries a disc of mass 500 kg at a radius of gyration of 450 mm. The modulus of rigidity for the shaft material is 80 GN/m. Determine the frequency of torsional vibrations. [4]

DEC 30 2018

8. Four masses A, B, C and D as shown below are to be completely balanced.

	A	B	C	D
Mass (kg)	---	30	50	40
Radius (mm)	180	240	120	150

The planes containing masses B and C are 300 mm apart. The angle between planes containing B and C is 90° . B and C make angles of 210° and 120° respectively with D in the same sense. Find

- (i) The magnitude and the angular position of mass A; and
(ii) The position of planes A and D.

[3]

[3]

