



7. Choose the **INCORRECT** statement
- The angle of contact in cross belt drive is more than that of open belt drive
  - In open belt drive, direction of rotation of two pulleys connected by it are same
  - For maximum power transmitted by belt, maximum tension in belt is twice the centrifugal tension in the belt.
  - Power transmitted by belt drive can be increased by increasing the initial tension in the belt
8. Which of the following statements are associated with complete dynamic balancing of rotating systems?
- A. Resultant couple due to all inertia forces is zero
  - B. Support reactions due to forces are zero but not due to couples
  - C. The system is automatically statically balanced
  - D. Centre of masses of the system lies on the axis of rotation.
- A, B, C and D     A, B and C only     B, C and D only     A, C and D only
9. In a radial cam, the follower moves
- in a direction perpendicular to the cam axis
  - in a direction parallel to the cam axis
  - in any direction irrespective of the cam axis
  - along the cam axis
10. The size of the gear is usually specified by
- pressure angle     circular pitch     number of teeth     pitch circle diameter
11. Interference can be avoided in involute gears with  $20^\circ$  pressure angle by
- cutting involute correctly     using as small number of teeth as possible
  - using more than 20 teeth     using more than 8 teeth
12. The train value of a gear train is
- equal to velocity of a gear train     reciprocal of velocity ratio of a gear train
  - always greater than unity     always less than unity
13. A combination of kinematic pairs, joined in such a way that the relative motion between the links is completely constrained, is called a
- structure     mechanism     kinematic chain     kinematic pair
14. Two kinematic links 1 and 2 are connected by a pin joint at O. If the link 1 and 2 rotates with angular velocity  $\omega_1$  and  $\omega_2$  rotating both in clockwise direction respectively, then the rubbing velocity at the pin joint O is
- $(\omega_1 + \omega_2).r$       $(\omega_1 - \omega_2).r$       $(\omega_1 - \omega_2).2r$       $\omega_1.\omega_2.r$
- Where  $r$  = radius of the pin at O.
15. A shaft running at 100 rpm is driving a parallel shaft at 300 rpm. If the diameter of the pulley on the driving shaft is 30 cm and belt thickness is 8 mm then diameter of the driven shaft pulley is
- 91.2 cm     90.8 cm     88.6 cm     88.2 cm

16 FEB 2025

16. The centrifugal tension in a belt drive system primarily affects which of the following?  
 power transmitted by a belt  
 initial tension in the belt  
 maximum tension the belt can withstand  
 frictional force between belt and pulley
17. If there are redundant constraints in the chain and it forms a statically indeterminate structure, what is the degree of freedom or the mobility of this structure?  
 0                       1                       2                       -1
18. If a gear has a module of 6 mm and 30 teeth, what is its circular pitch?  
 18.84 mm               22.62 mm               25.13 mm               28.26 mm
19. In a certain gear train, the driver has 18 teeth while the follower has 9 teeth. For every 18 turns of the driver, the follower turns  
 9                       18                       24                       36
20. When a point at the end of a link moves with constant angular velocity, its acceleration will have  
 radial components only  
 tangential components only  
 both radial and tangential components  
 no components as total acceleration is zero.



KATHMANDU UNIVERSITY  
End Semester Examination  
February, 2025

Level : B.E.  
Year : II  
Time : 2 hrs. 30mins.

16 FEB 2025

Course : MEEG 206  
Semester : II  
F. M. : 55

SECTION "B"

Attempt ALL questions.

1.

- a. Determine the degrees of freedom of the linkages shown in the figure below [4]

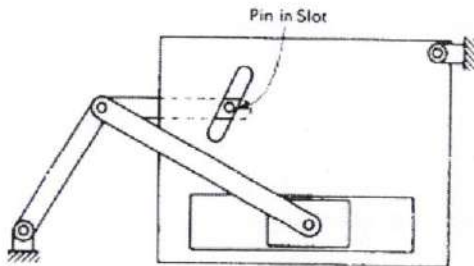

(i)

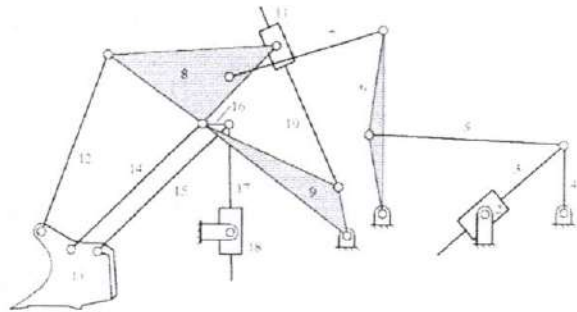

(ii)

- b. In the mechanism shown in the figure below, the crank AB rotates about A at uniform speed of 120 rpm in the clockwise direction. The lever DC oscillates about the fixed point D, which is connected to AB by the coupler BC. The block F moves in the horizontal guides, being driven by the link EF. Draw the configuration diagram and velocity diagram. Determine: [8]
- i. Velocity of the block F
  - ii. Velocity of point E, and
  - iii. Angular velocity of lever DC.

The lengths of various links are:  $AB = DE = 15$  cm;  $BC = CD = 45$  cm and  $EF = 37.5$  cm.

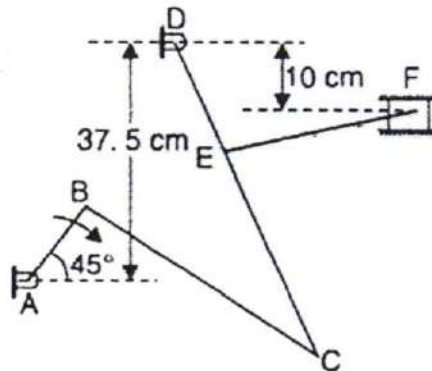

P.T.O.

2. A cam is to be used with a knife edge follower to operate a valve mechanism. The requirement of the valve movements are as follows: [11]
- Valve to move outwards through a distance of 40 mm during  $100^\circ$  of cam rotation.
  - Valve to dwell for the next  $80^\circ$  of cam rotation
  - Valve to return to its initial position during next  $90^\circ$  of cam rotation
  - Valve to dwell for the rest of the cam rotation.

The cam is rotating anticlockwise direction at a uniform speed of 900 rpm. The minimum radius of the cam is 50 mm and the line of stroke of the follower is offset 15 mm from the axis of the cam and the displacement of the follower is to take place with simple harmonic motion during out stroke and with uniform motion on the return strokes.

Draw the valve displacement diagram and the profile of the cam to obtain the required valve movement. Also determine the maximum velocity of the valve during outward and return stroke.

3. A transmission shaft, rotating at 500 rpm drives a milling machine which requires 3.75 kW at 750 rpm. A 300 mm diameter cast iron pulley is mounted on the transmission shaft. A preliminary design proposes using a belt 4.75 mm thick, which has a density of  $970 \text{ kg/m}^3$ . The allowable stress is 2 MPa. Two pulleys rotate in opposite directions and the centre distance of the shafts is 750 mm. The coefficient of friction is 0.3 for both pulleys. Determine the width of the belt taking centrifugal tension into account. [7]

4. A rotating shaft carries four unbalanced masses 18 kg, 14 kg, 16 kg and 12 kg at radii 5 cm, 6 cm, 7 cm and 6 cm respectively. The 2<sup>nd</sup>, 3<sup>rd</sup> and 4<sup>th</sup> masses revolve in planes 8 cm, 16 cm and 28 cm respectively measured from the plane of first mass and are angularly located at  $60^\circ$ ,  $135^\circ$  and  $270^\circ$  respectively measured anticlockwise from the first mass looking from this mass end of the shaft. The shaft is dynamically balanced by two masses, both located at 5 cm radii and revolving in planes mid-way between those of 1<sup>st</sup> and 2<sup>nd</sup> masses and midway between those of 3<sup>rd</sup> and 4<sup>th</sup> masses. Determine the magnitudes of the masses and their respective angular positions. [7]

- 5.
- State the law of gearing. [2]
  - Two mating involute spur gears of  $20^\circ$  pressure angle have a gear ratio of 2. The number of teeth on the pinion is 20 and its speed is 250 rpm. The module pitch of the teeth is 12 mm.

If the addendum on each wheel is such that the path of approach and the path of recess on each side are half the maximum possible length each, find: [8]

- The addendum for pinion and gear wheel
- The length of arc of contact
- The angle turned through by the larger wheel for one pair of teeth in contact.
- The maximum velocity of sliding during approach and recess.

Assume pinion to be driver.

16 FEB 2025

6. In the epicyclic gear train shown in the figure below, the compound wheels A and B as well as internal wheels C and D rotated independently about the axis O. The wheels E and F rotate on the pins fixed to the arm 'a'. All the wheels are of the same module. The number of teeth on the wheels A, B, E and F are 52, 56, 36 and 36 respectively. Determine the speed of wheel C if
- The wheel D fixed and arm 'a' rotates at 200 rpm clockwise
  - The wheel D rotates at 200 rpm counter-clockwise and the arm 'a' rotates at 20 rpm counter-clockwise

