

KATHMANDU UNIVERSITY
End Semester Examination [C]
November/December, 2023

Marks Scored:

Level : B.E.

Year : II

Exam Roll No. :

Time: 30 mins.

Course : MEEG 202

Semester : II

F. M. : 20

Registration No.:

Date 04 DEC 2023

SECTION "A"

[20 Q. × 1 = 20 marks]

Choose and mark [X] in the most appropriate option.

- The elongation of a circular tapered rod is given by _____.
 $\frac{4Pl}{\pi E d_1 d_2}$ $\frac{2Pl}{\pi E d_1 d_2}$ $\frac{4Pl}{E d_1 d_2}$ $\frac{4Pl}{\pi E d_1 d_2^2}$
- When a square or rectangular block subjected to a shear load is in equilibrium, the shear stress in one plane is always associated with a complementary shear stress (of equal value) in the other plane at _____ degrees to it.
 45 60 90 180
- The equivalent length of a column fixed at one end and free at the other end is _____.
 0.5 L 2 L 0.7 L 1.5 L
- The maximum compressive stress at the top of a beam is 1600 kg/cm^2 and the corresponding tensile stress at its bottom is 400 kg/cm^2 . If the depth of the beam is 10 cm, the neutral axis from the top is _____.
 2 cm 6 cm 4 cm 8 cm
- A beam is said to be of uniform strength, if
 B.M. is same throughout the beam
 Deflection is same throughout the beam
 Bending stress is same throughout the beam
 Shear stress is same throughout the beam
- The Moment of Inertia of hollow circular section about a central axis perpendicular to section as compared to its Moment of Inertia about horizontal axis is _____.
 Double Half Four times Same
- _____ of column mainly depends upon end conditions.
 Effective length Radius of gyration
 Slenderness ratio Factored load
- Calculate that torque, if the diameter of the shaft is 50 mm and revolutions @ 130 rpm. The maximum shear stress is 62.5 N/mm^2 .
 1564 Nm 1478 Nm 1534 Nm 1494 Nm

9. A circular shaft of diameter 30 mm is tested under torsion the gauge length of test specimen is 300 mm. A torque of 2kNm produces an angle twist of 1° . Calculate Modulus of rigidity of the specimen.
- $0.324 \times 10^6 \text{ N/mm}^2$ $0.432 \times 10^6 \text{ N/mm}^2$
 $0.46 \times 10^6 \text{ N/mm}^2$ $0.532 \times 10^6 \text{ N/mm}^2$
10. If two shafts are connected in parallel to each other, total torque t is applied on the composite shaft will be equal to
- torque in shaft 1 and torque in shaft 2 torque in shaft 1 – torque in shaft 2
 torque in shaft 2 – torque in shaft 1 torque in shaft 2 + torque in shaft 1
11. In cantilever beams, the slope is _____ at fixed end.
- Maximum Minimum Zero Uniform
12. In simply supported beams, deflection is zero at _____
- Mid span Supports
 Through out Point of action of load
13. The Von mises stress is given by the formula:
- $\sqrt{(\sigma_1 - \sigma_2)^2 + (\sigma_2 - \sigma_3)^2 + (\sigma_3 - \sigma_1)^2}$ $\sqrt{\frac{(\sigma_1 + \sigma_2)^2 - (\sigma_2 + \sigma_3)^2 - (\sigma_3 + \sigma_1)^2}{2}}$
 $\sqrt{\frac{(\sigma_1 - \sigma_2)^2 + (\sigma_2 - \sigma_3)^2 + (\sigma_3 - \sigma_1)^2}{2}}$ $\sqrt{\frac{(\sigma_1 + \sigma_2)^2 + (\sigma_2 + \sigma_3)^2 + (\sigma_3 + \sigma_1)^2}{3}}$
14. The maximum deflection in cantilever beam of span L m and loading at free end is “W” kN is _____
- $\frac{WL^3}{3EI}$ $\frac{WL^3}{4EI}$ $\frac{WL^3}{2EI}$ $\frac{WL^2}{2EI}$
15. Mohr’s Circle is often used to calculate
- Principal Deformation Principal Stress
 Modulus of Rigidity Beam Stiffness
16. Which of the following theories is suitable for ductile materials?
- Maximum Principal Stress Theory Maximum Principal Strain Theory
 Rankine Theory Maximum Shear Stress Theory
17. At a certain point in a structural member, the value of $\sigma_x = -45 \text{ N/mm}^2$, $\sigma_y = 75 \text{ N/mm}^2$ and $\tau = 45 \text{ N/mm}^2$. The principal stresses will be
- 120 N/mm^2 and 30 N/mm^2 120 N/mm^2 and -30 N/mm^2
 90 N/mm^2 and 60 N/mm^2 90 N/mm^2 and -60 N/mm^2
18. The angle between Major Principal Plane and Minor Principal Plane for a strained body is _____
- 45° 90° 60° 30°

19. The distortion energy theory is based on the work of

Rankine

Tresca

Von-Mises, Hencky and Huber

Beltrami

20. Which of these are types of normal stresses?

Tensile and compressive stresses

Shear and bending

Tensile and thermal stresses

Compressive and plane stresses

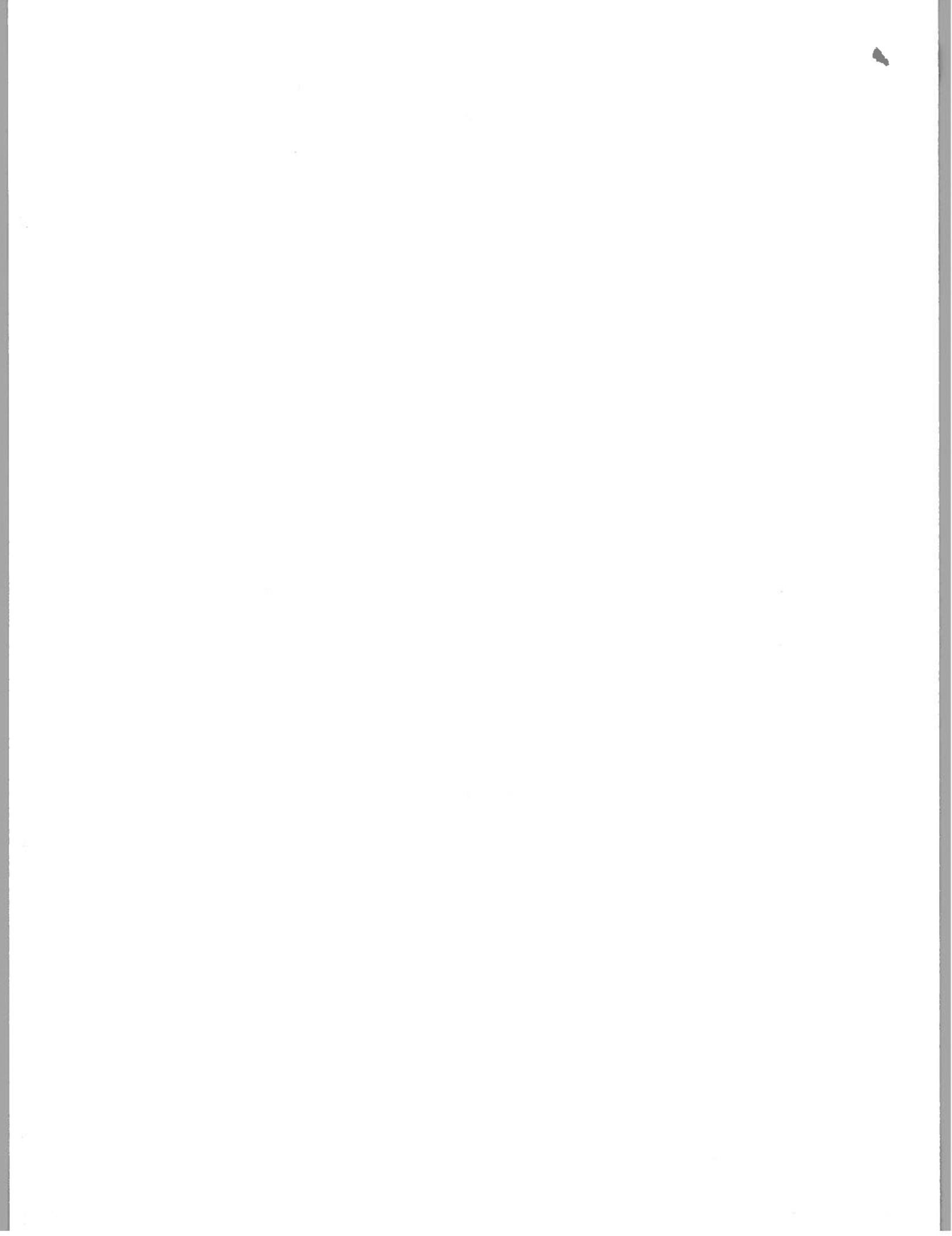

KATHMANDU UNIVERSITY
End Semester Examination [C]
November/December, 2023

04 DEC 2023

Level : B.E.
Year : II
Time : 2 hrs. 30 mins.

Course : MEEG 202
Semester : II
F. M. : 55

SECTION "B"

Attempt *ALL* questions. Assume data if missing.

1. A brass bar, having cross-sectional area of 500 mm^2 is subjected to axial forces as shown in figure. Find the total elongation of the bar. Take $E = 80 \text{ GPa}$. [4]

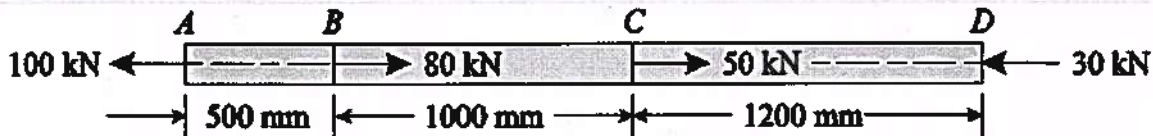

2. A Cast Iron flat, 300 mm long with 30 mm thick and 50 mm wide uniform section is acted upon by the following forces uniformly distributed over the respective cross-section; 25 kN in the direction of length (tensile); 350 kN in the direction of the width (compressive); and 200 kN in the direction of thickness (tensile). Determine the change in the volume of the flat if $E = 140 \text{ GN/m}^2$ and $\mu = 0.25$. [5]
3. The 2000 - lb load may be moved along the beam BD to any position between stops at E and F. Knowing that $\sigma_{\text{Allowable}} = 6 \text{ ksi}$ for the steel used in rods AB and CD, determine where the stops should be placed if the permitted motion of the load is to be as large as possible. [5]

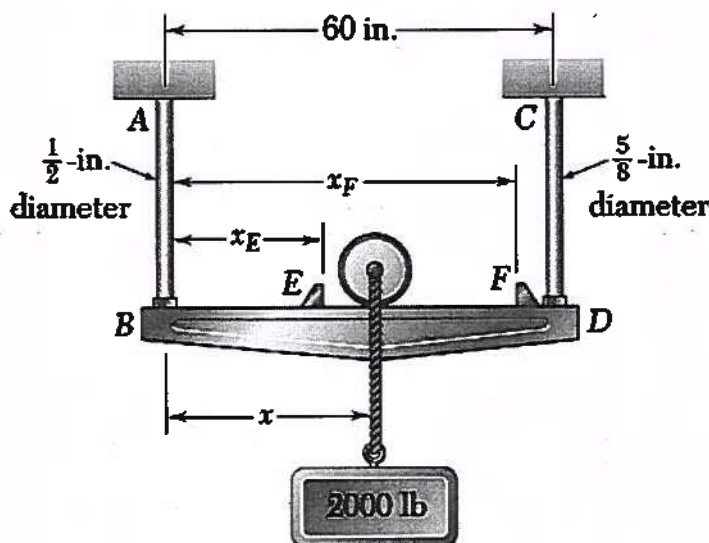

4. a. Two mutually perpendicular planes of an element of material are subjected to direct stresses of 10.5 MN/m^2 (tensile) and 3.5 MN/m^2 (compression) and shear stress of 7 MN/m^2 . Find graphically or analytically the magnitude of the principal stresses and the direction of the principal stresses [2+2]
- b. If the element above has a yield point in simple tension and compression of 180 MPa and Poisson's ratio of 0.25, what is the factor of safety of the element according to maximum principal strain theory? [3]
5. a. A simply supported beam 6 m long is loaded. Construct the shear force and bending moment diagrams for beam and find the value of maximum bending moment. [7]

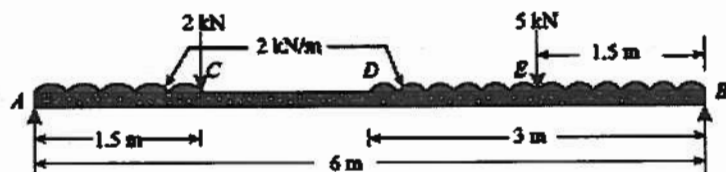

- b. The beam above is of rectangular cross-section 0.8 mm wide and 2.5 mm deep. What is the value of maximum bending stress that occurs in the beam? [3]
6. The rigid bar DEF is welded at point D to the steel beam AB. For the loading shown, determine
- a. the equation/s defining shear and bending moment for sections of the beam [4]
- b. the equation of the elastic curve for the sections of the beam [4]
- c. the deflection at the midpoint C of the beam. Use $E = 29 \times 10^6 \text{ psi}$. [2]

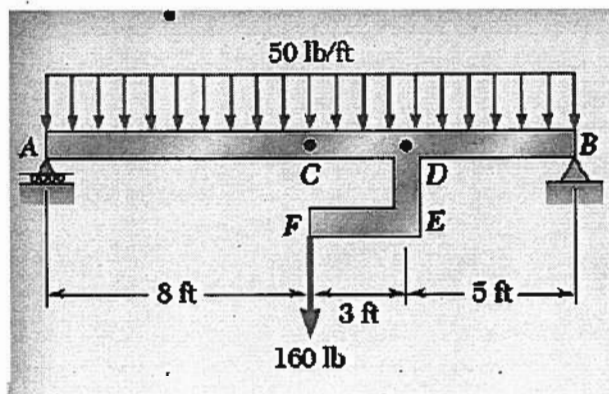

7. A hollow alloy tube 4 m long with external and internal diameters of 40 mm and 25 mm respectively was found to extend 4.8 mm under a tensile load of 60 kN. Find the buckling load for the tube with both ends pinned. Also find the safe load on the tube, taking factor of safety as 5. [4]

8. a. Explain briefly the failure behaviors of ductile and brittle materials subjected to pure torsion. [3]
- b. The design of the gear-and-shaft system shown requires that steel shafts of the same diameter be used for both AB and CD. It is further required that $\tau_{max} \leq 60 \text{ MPa}$ and that the angle ϕ_D through which end D of shaft CD rotates not exceed 1.5° . Knowing that $G = 77 \text{ GPa}$, determine the required diameter of the shafts. [7]

