



10. Line of collimation is defined as:
- Line joining the intersection of cross hair, Optical center of objective and its continuation
  - Line joining the center of eye piece and optical center of objective
  - Line tangential to the longitudinal curve of the bubble tube at midpoint
  - Inclined line of sight
11. Why is the danger circle problematic in resection?
- It causes significant errors in angle measurement
  - It causes the instrument to lose its calibration
  - It requires more complex mathematical calculations
  - It makes it difficult to accurately determine the instrument's position
12. For the distance of 160km, the total number of permanent benchmarks required is \_\_\_\_\_
- 160
  - 142
  - 180
  - 320
13. The number of checks for single triangle in Trilateration is?
- 0
  - 1
  - 2
  - 4
14. Which of the following is the not the method of adjusting a closed traverse?
- Graphical Method
  - Axis Method
  - Transit Method
  - Tienstra Method
15. The height of the wave compared to undisturbed state is known as
- Frequency
  - Crest
  - Trough
  - Amplitude
16. Which of the following is a key requirement for performing theodolite resection?
- Three known points and distances between them.
  - Two known points and one unknown point.
  - Three known points and the angles between them
  - One known point and the distance to the unknown point
17. If the linear accuracy of a traverse is 1:5000, corresponding angular accuracy is:
- 20.63"
  - 41.25"
  - 3'26"
  - 2"
18. What is the primary purpose of profile levelling?
- To determine the elevation difference between two points
  - To determine the elevation across the line to determine earth works
  - To find the elevation along a line for construction projects
  - To measure vertical angles
19. The distance of visible horizon D at a height of H is:
- $D = 0.0675 * H^2$
  - $D = 0.0675 * H$
  - $D = \sqrt{\frac{H}{0.0673}}$
  - $D = \sqrt{\frac{H}{0.673}}$
20. The recommended distance between two stations in second order triangulation is:
- 3-7 km
  - 9-15 km
  - 0.2-2 km
  - 20-30 km

KATHMANDU UNIVERSITY  
End Semester Examination  
March/April, 2025

Level : B.E.  
Year : II  
Time : 2 hrs. 30mins.

Course : GEOM 202  
Semester : I  
F. M. : 40

08 APR 2025

SECTION "B"

[6Q. × 4 = 24 marks]

Attempt ANY SIX questions.

1. Define well-conditioned Triangle and Derive the condition for well-Conditioned Triangle with appropriate figure. [1+3]
2. Define EDM along with its fundamental Principles. Shortly describe RDM and REM functions of Total Station. [2+2]
3. What is a Danger Circle? Given the coordinates of points S (2385.652 m, 1925.503 m) and A (2732.454 m, 1720.806 m), along with the observed angles at these stations, determine the coordinates of point B based on the provided layout of the stations. [1+3]

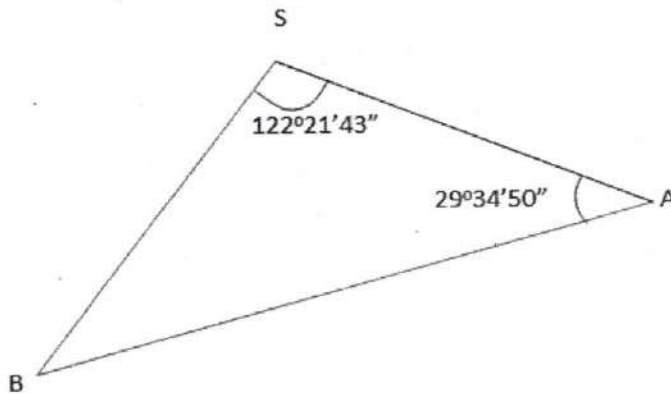

4. The following notes refer to the reciprocal levels taken with one level. Find
  - a. True RL of B [1]
  - b. Combined correction for curvature and refraction [1]
  - c. The error in collimation adjustment of the instrument [2]

Instrument station	Staff readings on		Remarks
	A	B	
A	1.03	1.730	Distance AB= 950m
B	0.75	1.430	RL of A=1400.66 m

P.T.O.

5. Briefly describe different methods of Traverse Adjustment. [4]
6. There are two stations A and B at elevations of 185 m and 945m, respectively. The distance of Q from P is 100 km. If the elevation of a peak M at a distance of 40 km from P is 310 m, determine whether B is visible from A or not. If not, what would be the height of scaffolding required at B so that B becomes visible from A? [4]
7. Write short notes on: [2+2]
- Trilateration
  - Fundamental Lines of theodolite and their geometry

SECTION "C"

[2 Q. × 8 = 16 marks]

Attempt *ANY TWO* questions.

8. The table below provides angular and linear observations for a closed-loop traverse **ABCDEF**, conducted in a **clockwise** direction. The coordinates of point **A** and a reference origin (**RO**) are given. Determine the coordinates of points **B, C, D, E, and F** using the given data. Apply the **Equal Shift Method** for angular adjustment and the **Bowditch Rule** for linear misclosure. [8]

Station	Angles observed (Gon)	Length	Easting	Northing
RO	-	-	<b>633165.388</b>	<b>3050922.999</b>
A	323.8160	505.375	<b>633237.282</b>	<b>3050527.245</b>
B	213.1945	206.841		
C	322.5672	236.597		
D	275.8620	337.853		
E	213.9152	67.795		
F	218.5126	242.853		
A	32.1234	-		
RO	-	-		

9. Define Horizontal and Vertical Datum with suitable examples. The following consecutive readings were taken with a level and 5m levelling staff on continuously slopping ground at a common interval of 20m: 0.385; 1.030; 1.925; 2.825; 3.730; 4.685; 0.625; 2.005; 3.110; 4.485. The reduced level of the first point was 1350m. Rule out a page of a level field book and enter the above readings. Calculate the reduced levels of the points by rise and fall method and also the gradient of the line joining the first and the last point. [2+4+2]

10. List out angle and side conditions for adjustment of braced quadrilateral with appropriate figure. Compute the strength of the figure ABCD for all the routes by which the length BD can be computed from the known side AC. Assume that all the stations were occupied. [2+6]

