

KATHMANDU UNIVERSITY
End Semester Examination
February/March, 2018

Marks Scored:

Level : B. E.

Year : IV

Exam Roll No. :

Time: 30 mins.

Course : EPEG 413

Semester: I

F. M. : 20

Registration No.:

Date FEB 26 2018

SECTION "A"

[20 Q. × 1 = 20 marks]

Choose and **encircled** the most appropriate answer.

1. For a purely inductive circuit
 - a. the current lags the voltage by 90° and there is transformation of energy with minimum average power.
 - b. the current lags the voltage by 90° and there is no transformation of energy with maximum average power.
 - c. the voltage lags the current by 90° and there is no transformation of energy with maximum average power.
 - d. the current lags the voltage by 90° and there is no transformation of energy with zero average power.

2. For a typical power system with small R/X ratio,
 - a. small changes in δ_1 and δ_2 will have significant effect on the reactive power flow where as small changes in voltage magnitude will not have appreciable effect on the real power flow.
 - b. small changes in δ_1 and δ_2 will have significant effect on the real power flow where as small changes in voltage magnitude will not have appreciable effect on the real power flow
 - c. small changes in δ_1 and δ_2 will have significant effect on the real power flow where as small changes in voltage magnitude will not have appreciable effect on the reactive power flow
 - d. small changes in δ_1 and δ_2 will have less effect on the real power flow where as small changes in voltage magnitude will not have appreciable effect on the real power flow

3. Load models when considered as a negative power injection into the network is called
 - a. constant impedance model
 - b. constant current model
 - c. constant power model
 - d. constant voltage model

4. In the figure 1 the bus admittance matrix is

a.
$$\begin{bmatrix} -j8.75 & j2.5 & j5.0 & 0 \\ j2.5 & -j8.5 & j5.0 & 0 \\ j5.0 & j5.0 & -j12.5 & j12.5 \\ 0 & 0 & j12.5 & -j12.5 \end{bmatrix}$$

b.
$$\begin{bmatrix} -j8.5 & j2.5 & j5.0 & 0 \\ j2.5 & -j8.75 & j5.0 & 0 \\ j5.0 & j5.0 & -j22.5 & j12.5 \\ 0 & 0 & j12.5 & -j12.5 \end{bmatrix}$$

c.
$$\begin{bmatrix} -j8.5 & j2.5 & j6.0 & 0 \\ j2.5 & -j8.75 & j5.0 & 0 \\ j5.0 & j5.0 & -j22.5 & j12.5 \\ 0 & 0 & j12.5 & -j12.5 \end{bmatrix}$$

d.
$$\begin{bmatrix} -j8.5 & j2.5 & j5.0 & 0 \\ j2.5 & -j8.75 & j5.0 & 0 \\ j5.0 & j5.0 & -j22.5 & j22.5 \\ 0 & 0 & j12.5 & -j12.5 \end{bmatrix}$$

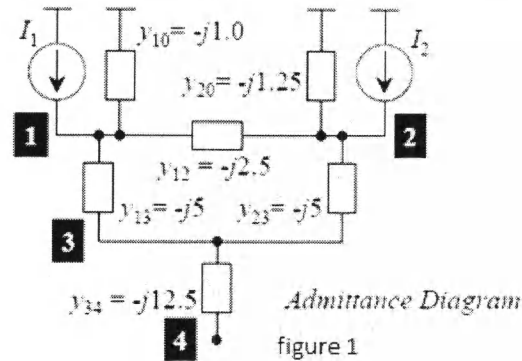

5.

Node	U_{pu}	δ°	P_{pu}	Q_{pu}
1	1.0	0	---	---
2	1.0	---	-1.0	---
3	---	---	-0.8	-0.6

From the table given above node 1, 2 and 3 represents

- slack bus, load bus and PV bus respectively.
- load bus, slack bus and PV bus respectively.
- slack bus, PV bus and load bus respectively.
- reference bus, slack bus and load bus respectively.

6. The unbalanced currents are $I_a=100\angle 30^\circ$, $I_b=50\angle 300^\circ$ and $I_c=30\angle 180^\circ$. The symmetrical components of these unbalanced currents are

- $I_{a0} = 27.29\angle 4.69^\circ$, $I_{a1} = 57.98\angle 43.29^\circ$, $I_{a2} = 18.97\angle 24.96^\circ$
- $I_{a0} = 30\angle 4.69^\circ$, $I_{a1} = 57.98\angle 43.29^\circ$, $I_{a2} = 18.97\angle 24.96^\circ$
- $I_{a0} = 27.29\angle 4.69^\circ$, $I_{a1} = 50\angle 43.29^\circ$, $I_{a2} = 18.97\angle 24.96^\circ$
- $I_{a0} = 30\angle 4.69^\circ$, $I_{a1} = 57.98\angle 43.29^\circ$, $I_{a2} = 30\angle 24.96^\circ$

FEB 26 2018

7. Variables are calculated by power flow equations
- 1 real power P , at reference bus, (n-s) reactive power Q , at PV buses and the reference buses, s voltages V at PQ buses, (n-1) angle δ , all buses except the reference bus
 - 1 real power P , at PV bus, (n-s) reactive power Q , at reference buses, s voltages V at PQ buses, (n-1) angle δ , all buses except the reference bus
 - 1 real power P , at reference bus, (n-s) reactive power Q , at PQ buses, s voltages V at PV buses, (n-1) angle δ , all buses except the reference bus
 - 1 real power P , at reference bus, (n-s) reactive power Q , at PQ buses and the reference buses, s voltages V at PV buses, (n-1) angle δ , all buses except the reference bus
8. The impedance matrix has nonzero elements appearing only on the principal diagonal, and it is a diagonal matrix. Therefore for a balanced load,
- the three sequences are dependent. i.e. currents of each phase seq. will produce voltage drops of the same phase sequence only. This is very important property, as it permits the analysis of each sequence network on a per phase basis.
 - the three sequences are independent. i.e. currents of each phase seq. will produce voltage drops of the different phase sequence. This is very important property, as it permits the analysis of each sequence network on a per phase basis.
 - the three sequences are independent. i.e. currents of each phase seq. will produce voltage drops of the same phase sequence only. This is very important property, as it permits the analysis of each sequence network on a per phase basis.
 - the three sequences are dependent. i.e. currents of each phase seq. will produce voltage drops of the different phase sequence only. This is very important property, as it permits the analysis of each sequence network on a per phase basis.
9. The three phase synchronous generator delivers 10 MVA at a voltage of 10.5 kV. The line impedance is 5Ω . Using the reference base as 12 MVA at 11 kV, the voltage drop in the line in per unit is _____.
- a. 0.4329 b. 0.8730 c. 0.4958 d. 0.1050
10. Equal area criteria gives the information regarding
- Stability region
 - Swing Curves
 - Absolute Stability
 - Relative Stability
11. The stability of the power system is not affected by
- Generator reactance
 - Line reactance
 - Excitation of the generator
 - Line losses
12. What will be the inertia constant H , for a water wheel generator having a speed less than 200 rpm?
- a. 1 - 2 b. 2 - 3 c. 2 - 4 d. 3 - 4
13. Fault level means
- voltage at the point of fault
 - fault current
 - fault power factor
 - fault MVA

14. Load flow study is carried out for
a. load frequency control
b. system planning
c. stability studies
d. fault calculation
15. The positive sequence component of voltage at the point of fault becomes zero when it is
a. three phase fault
b. line to line fault
c. LLG fault
d. line to ground fault
16. In which type of the fault given below, all the 3 components I_{a0} , I_{a1} and I_{a2} are equal
a. single line to ground fault
b. line to line fault
c. double line to ground fault
d. none to the above
17. By using the method of equal area criterion, system will be stable when Area A1, and areas A2 are
a. unequal
b. equal
c. infinity
d. oscillatory
18. For a single line to ground fault the zero sequence current is given by $j3.0$ pu. The current carried by the neutral during the fault is
a. $j 1.0$
b. $j3.0$
c. $j9.0$
d. $j6.0$
19. A symmetrical fault on a power system is _____ an unsymmetrical fault
a. More severe and more occurrence than
b. More severe and less occurrence than
c. less severe and more occurrence than
d. less severe and less occurrence
20. During load shedding
a. system voltage is reduced
b. system frequency is reduced
c. system power factor is changed
d. some load are switched off

KATHMANDU UNIVERSITY
End Semester Examination
February/March, 2018

FEB 26 2018

Level : B. E.
Year : IV
Time : 2 hrs. 30 mins.

Course : EPEG 413
Semester: I
F. M. : 55

SECTION "B"

Attempt **any FIVE** questions. Each question carries 11 marks. Assume relevant values if necessary.

Question 1 (Basic concept and system modelling)

- 1.1. A single phase voltage of 240V is applied to a series circuit whose impedance is $10 \angle 60^\circ \Omega$. Find R,X,P,Q and the power factor of the circuit. [3]
- 1.2. What do you mean by power apparatus modeling of power system? Explain. [4]
- 1.3. The reactance of a generator designated X'' is given as 0.25 per unit based on the generator's nameplate rating of 28 kV, 400 MVA. The base for calculations is 30 kV, 100 MVA. Find X'' on the new base. [4]

Question 2 (Load Flow Solutions and Control)

- 2.1 A three bus power system is shown in figure 2.1. The relevant per unit line admittances on 100MVA base are indicated on the diagram and bus data are given in the table 2.

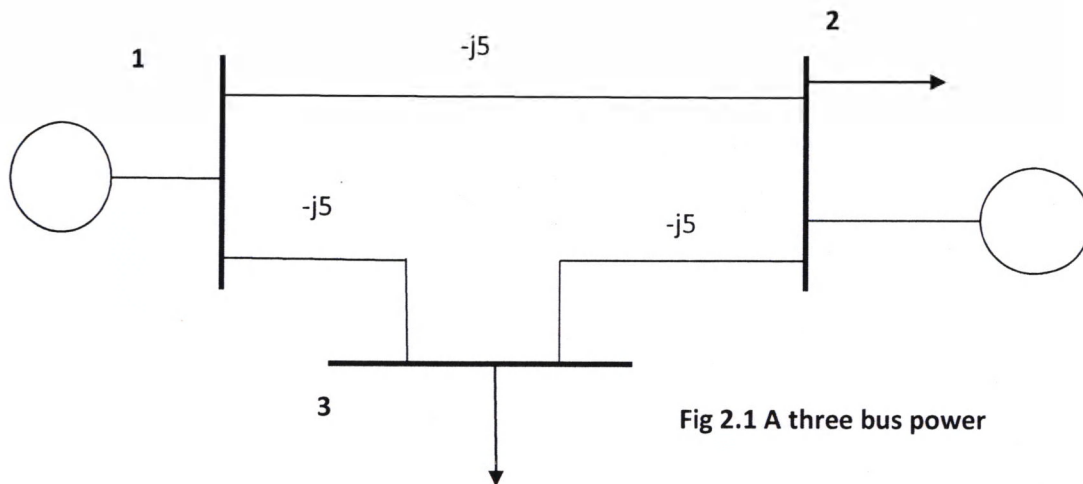

Table 2

Bus number	Type	Generation		Load		Bus Voltage	
		P_G (MW)	Q_G (MVA)	P_L (MW)	Q_L (MVA)	V pu	δ deg.
1	Slac	?	?	0	0	1.02	0°
2	PQ	30	10	60	25	?	?
3	PQ	0	0	50	30	?	?

Form Y_{bus} and determine the voltages at bus 2 and 3 after **first iteration using Gauss-Seidel** method. [7]

- 2.2 List out the advantages and limitation of Gauss Seidel and Newton Raphson methods in power flow studies. [4]

Question 3(Symmetrical Three Phase Faults)

- 3.1 . Two generators are connected in parallel to the low voltage side of a three phase Δ -Y transformer as shown in figure 3.1. Generator 1 is rated 50,000 kVA, 13.8 kV. Generator 2 is rated 25,000 kVA, 13.8 kV. Each generator has a subtransient reactance of 25%. The transformer is rated 75,000 kVA, 13.8 Δ / 69Y kV, with a reactance of 10%. Before the fault occurs, the voltage on the high tension side of the transformer is 66 kV. The transformer is unloaded, and there is no circulating current between the generators. Find the subtransient current in each generator when a three phase short circuit occurs on the high tension side of the transformer.

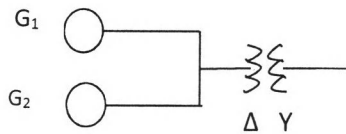

Figure3.1

[6]

- 3.2 Determine Z_{bus} for the network shown in fig. 3.2 with 0-1,1-2,2-3,3-0. The impedances are shown in per unit.

Preserve all three nodes.

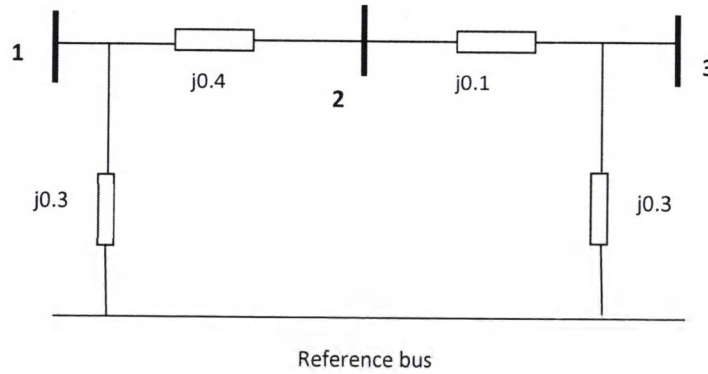

Fig 3.2

[5]

Question 4(Symmetrical Components)

- 4.1 Draw the zero sequence network for the system shown in figure 4.1

[6]

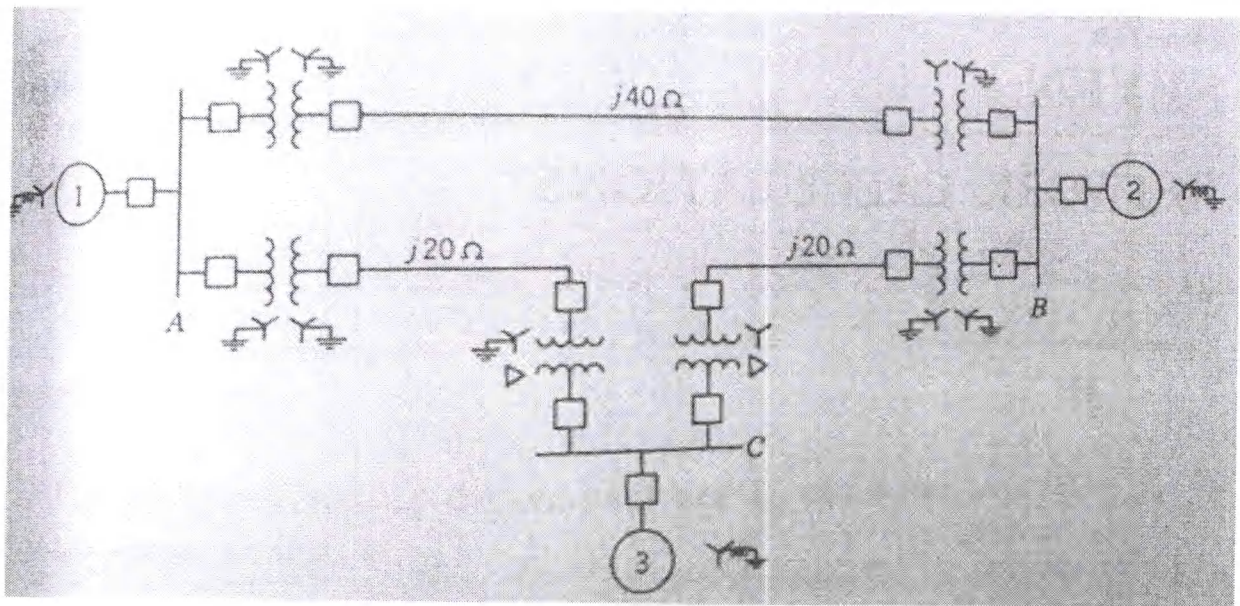

Fig 4.1

- 4.2 Determine the symmetrical components of the three currents. Show them with the help of graphical addition of component to obtain three unbalance phasors.

$I_a = 10 \angle 0^\circ \text{ A}$

$I_b = 10 \angle 230^\circ \text{ A}$

$I_c = 10 \angle 130^\circ \text{ A}$

[3+2]

Question 5(Unsymmetrical Faults)

- 5.1 Derive the expression for double line to ground fault on an unloaded generator. Also show the connection of the sequence networks of an unloaded generator for a double line to ground fault on phases **b** and **c** at the terminals of the generator. [3+3]
- 5.2 A salient pole generator without dampers is rated 20 MVA, 13.8 kV and has a direct axis sub-transient reactance of 0.25 per unit. The negative and zero sequence reactances are 0.35 and 0.10 per unit respectively. The neutral of the generator is solidly grounded. Determine the sub-transient current in the generator and the line to line voltages for sub-transient conditions when a line to line fault occurs at generator terminals with the generator operating unloaded at rated voltage. Neglect resistance. [5]

Question 6 (Power system Stability and Short notes)

- 6.1 State Equal Area Criterion for transient stability. Explain the effect of sudden change in mechanical input to a generator tied to infinite bus using equal area criteria. [4]
- 6.2 The generator of Fig.6.1 is delivering 1.0 pu power to the infinite bus ($|V| = 1.0$ pu), with the generator terminal voltage of $|V_t| = 1.0$ pu. Calculate the generator emf behind transient reactance. Find the maximum power that can be transferred under the following conditions: (i) System healthy (ii) One line shorted in the middle. Also draw the power angle curves for the two cases.

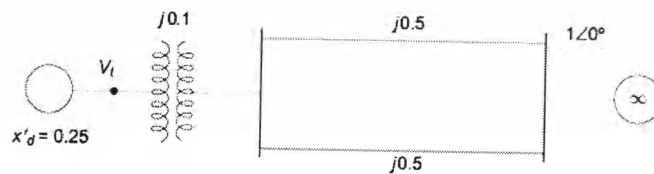

Fig.6.1

- 6.3 Write short notes on (any *three*) [4]
1. Growth of electricity from 19th century
 2. Swing equation
 3. Combinations of Y- Δ transformer banks
 4. Transient stability

[3 \times 1=3]