

KATHMANDU UNIVERSITY
End Semester Examination
March, 2025

Level : B.E.
Year : II
Time : 2 hrs. 30mins.

20 MAR 2025

Course : ENVE 206
Semester : I
F. M. : 40

SECTION "B"

[2Q. × 7 = 14 marks]

Attempt **ALL** questions. *All the necessary constants and values are given in italics.*

1. A gas stream containing 8.0 mol% CO and 92.0 mol% CO₂ at 500°C is fed to a waste heat boiler, a large metal shell containing a bundle of small-diameter tubes. The hot gas flows over the outside of the tubes. Liquid water at 25°C is fed to the boiler in a ratio 0.200 mol feed water/mol hot gas and flows inside the tubes. Heat is transferred from the hot gas through the tube walls to the water, causing the gas to cool and the water to heat to its boiling point and evaporate to form saturated steam at 5.0 bar. The steam may be used for heating or power generation in the plant or as a feed to another process unit. The gas leaving the boiler is flared and discharged to the atmosphere. The boiler operates adiabatically - all the heat transferred from the gas goes to the water, as opposed to some of it leaking through the outside boiler wall. The flowchart for an assumed basis of 1.00 mol feed gas is shown below. What is the temperature of the exiting gas?

Given:

Reference state: CO, CO₂, H₂O

H₂O (l, triple point)

CO and CO₂ (500 C, g, 1 atm)

H₃ = 105 kJ/kg

H₄ = 2747.5 kJ/kg

C_p value of CO = 0.02895 + (0.4110 × 10⁻⁵ T) + (0.3548 × 10⁻⁸ T² - 2.22 × 10⁻¹² T³)

C_p value of CO₂ = 0.3611 + (4.223 × 10⁻⁵ T) - (2.887 × 10⁻⁸ T²) + (7.464 × 10⁻¹² T³)

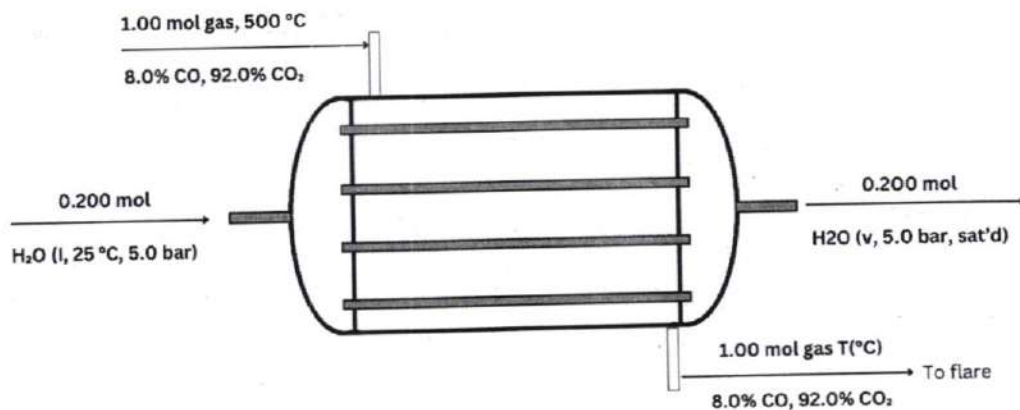

P.T.O.

2. Figure shows the process and the known data. Calculate the compositions of every flow stream, and the fraction of the sugar in the cane that is recovered.

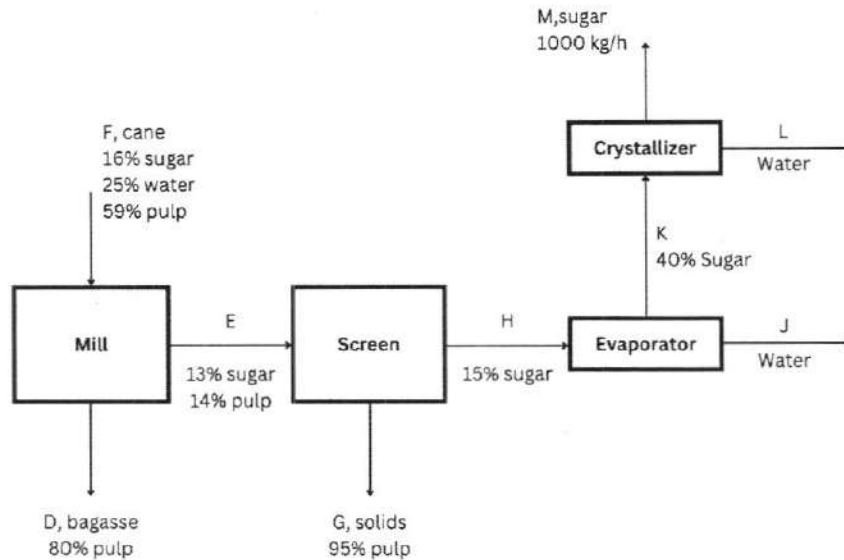

SECTION "C"

Attempt **ALL** questions.

3. Define the following terms: [5Q × 1 = 5 marks]
- Closed system
 - Unsteady state system
 - Law of Conservation of mass
 - Volumetric fraction
 - Specific density
4. Differentiate between: [2Q × 2.5 = 5 marks]
- Material Balance and Energy Balance
 - Reactive and Non-Reactive Systems
5. A gas stream contains 80% nitrogen and 20% oxygen by volume. If the total mass flow rate of the gas is 500 kg/h, determine the mass flow rates of nitrogen and oxygen in: [2Q × 1.5 = 3 marks]
- kg/h
 - g/s

6. Five hundred kilograms per hour of steam drives a turbine. The steam enters the turbine at 44 atm and 450°C at a linear velocity of 60 m/s and leaves at a point 5 m below the turbine inlet at atmospheric pressure and a velocity of 360 m/s. The turbine delivers shaft work at a rate of 70 kW, and the heat loss from the turbine is estimated to be 104 kcal/h. Calculate the specific enthalpy change associated with the process. [3 marks]
- Given:

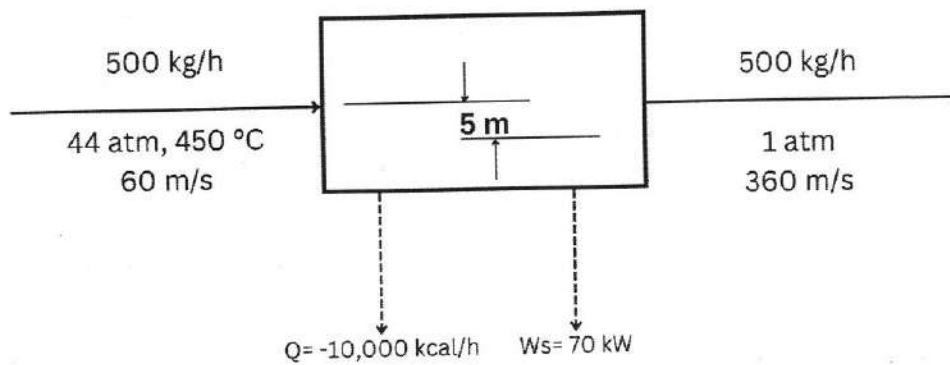

7. Streptomycin is used as an antibiotic to fight bacterial diseases in humans as well as to control bacteria, fungi, and algae in crops. First an inoculate is prepared by placing spores of strains of *Streptomyces griseus* in a medium to establish a culture with a high biomass. The culture is then introduced into a fermentation tank which operates at 28°C and a pH of about 7.8 with the nutrients of glucose (the carbon source) and soybean meal (the nitrogen source). High agitation and aeration are needed. After fermentation, the biomass is separated from the liquid, and Streptomycin is recovered by adsorption on activated charcoal followed by extraction with an organic solvent in a continuous extraction process. If we ignore the details of the process and just consider the overall extraction process, the figure below shows the net result. Determine the mass fraction of Streptomycin in the exit organic solvent based on the data in figure below, assuming that no water exits with the solvent and no solvent exits with the aqueous solution. Assume that the density of the aqueous solution is 1 g/cm³ and the density of the organic solvent is 0.6 g/cm³. [5 marks]

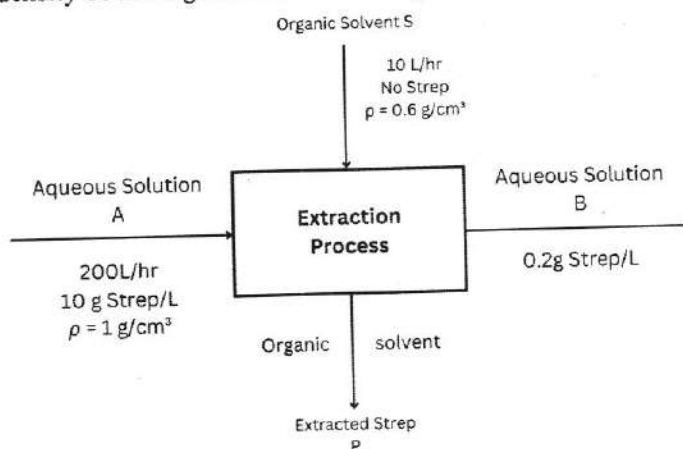

8. Membranes represent a relatively new technology for the commercial separation of gases. One use that has attracted attention is the separation of nitrogen and oxygen from air. Figure below illustrates a nanoporous membrane which is made by coating a very thin layer of polymer on a porous graphite supporting layer. What is the composition of the waste stream if the waste stream amounts to 80% of the input stream? [5 marks]

