

KATHMANDU UNIVERSITY  
End Semester Examination  
June/July, 2023

Marks Scored:

Level : B.Tech.

Course : ENVE 205

Year : II

Semester : II

Exam Roll No. :

Time: 30 mins.

F. M. : 20

Registration No.:

Date **02 JUL 2023**

SECTION "A"

[20 Q. × 1 = 20 marks]

Encircle the most appropriate option.

1. A rod 150 cm long and a diameter of 2 cm is subjected to an axial pull of 20 kN. If the modulus of elasticity of the rod of the material is  $2 \times 10^5$  N/mm<sup>2</sup>. The stress is  
a. 63.662 N/mm<sup>2</sup>    b. 63.662 N/cm<sup>2</sup>    c. 63.662 kN/mm<sup>2</sup>    d. 0.63 N/mm<sup>2</sup>
2. The elongation of the rod of problem 1 is  
a. 0.0477 cm    b. 0.477 cm    c. 4 cm    d. 0.04 cm
3. A brass bar having cross section area of 1000 mm<sup>2</sup> is subjected to forces as shown in figure

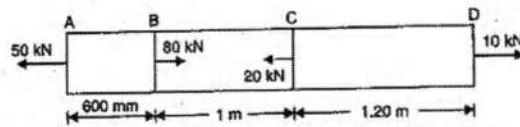

Take  $E = 1.05 \times 10^5$ . The total elongation of the bar is

- a. 0.2095 mm    b. -0.1142 mm    c. 0.1142 mm    d. 0.2857 mm
4. The ratio of tensile stress (compressive stress) to its corresponding strain is known as  
a. modulus of rigidity    b. poisson's ratio  
c. modulus of elasticity    d. bulk modulus
5. The stress induced in a body, which is subjected to two equal and opposite pushes is known as  
a. longitudinal stress    b. tensile stress  
c. volumetric stress    d. compressive stress
6. A rod of 2 m long is at a temperature of 10<sup>0</sup>C. Find the extension of the rod when the temperature is raised to 80<sup>0</sup>C. Take  $E = 1 \times 10^5$  MN/m<sup>2</sup> and  $\alpha = 0.000012$  per degree centigrade.  
a. 1.68 cm    b. 0.168 cm    c. 0.0168 cm    d. 1.58 mm
7. The total extension of a uniformly tapering rod of diameter D<sub>1</sub> and D<sub>2</sub> when the rod is subjected to an axial load of P is given by  
a.  $4 PL / ED_1 D_2$     b.  $4 PL / \pi E D_1 D_2$     c.  $PL / E D_1 D_2$     d.  $PL / ED_1 D_2$
8. Using analytical method, determine the center of gravity along x-axis of the plane uniform lamina as shown in figure.  
a. 7.11 cm    b. 3.22 cm  
c. 5 cm    d. 4.32 cm
9. Moment of inertia of a triangular section about an axis passing through C.G. and parallel to base is  
a.  $bh^3/12$     b.  $bh^3/3$     c.  $bh^3/64$     d.  $bh^3/36$

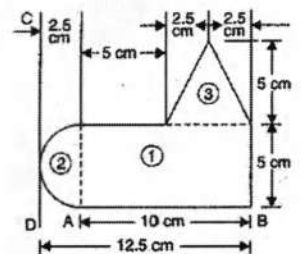

10. Find the maximum shear force of the beam with loaded as shown in figure is

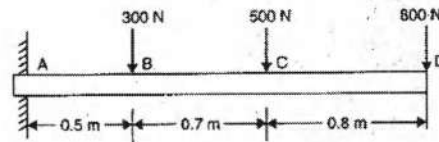

- a. 1550 N                      b. 1600 N                      c. 640 N                      d. 2000 N
11. The maximum bending moment of problem 10 is  
a. 1550 Nm                      b. - 1550 Nm                      c. - 2350 Nm                      d. 2350 Nm
12. The cantilever beam of length  $L$  fixed at end A and carrying a uniformly distributed load of  $w$  per Unit length over the entire length of cantilever. The maximum bending moment is  
a.  $wL^2/4$                       b.  $-WL/4$                       c.  $wL^2/8$                       d.  $-wL^2/2$
13. When a beam is subjected to a couple at a section, then bending moment changes suddenly at the section but ..... remains unaltered at the section.  
a. shear force                      b. bending moment  
c. maximum bending moment                      d. point load
14. Relation between  $E$ ,  $G$  and  $K$  is  
a.  $9 KG/(3K + G)$                       b.  $KG/(3K+G)$                       c.  $3 KG/(3K +G)$                       d.  $3KG/(9K+G)$
15. Bulk modulus is defined as the ratio of Normal stress by ..... strain.  
a. linear strain                      b. compressive strain  
c. lateral strain                      d. volumetric strain

**Define in one sentence**

16. Uniformly varying load
17. Modulus of rigidity
18. Statistically determinant structures
19. Statistically indeterminant structures
20. Poisson's ratio

Level : B.Tech.  
Year : II  
Time : 2 hrs. 30 mins.

Course : ENVE 205  
Semester : II  
F. M. : 55

SECTION "B"

Attempt ALL questions.

1. Draw the shear force and bending moment diagram of the beam shown in the figure 1. [10]

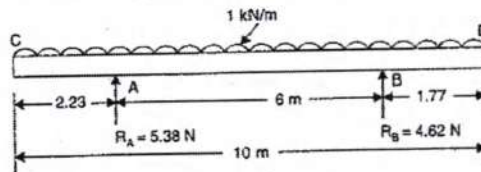

Figure 1

2. A cast iron beam of T section is shown in figure 2. The beam is simply supported on a span of 8 m. The beam carries a uniformly distributed load of 1.5 kN/m length on the entire span. Determine the maximum tensile and maximum compressive stress. [7]

Use  $\frac{M}{I} = \frac{\sigma}{y}$

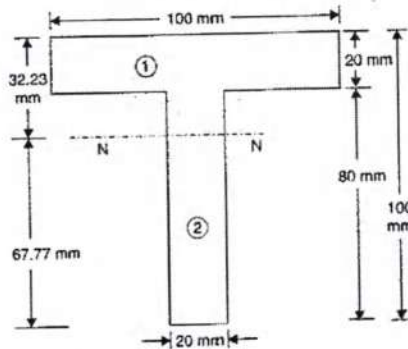

Figure 2

3. Find the moment of inertial of the centroidal XX and centroidal YY axis of the section as shown in figure 3. [7]

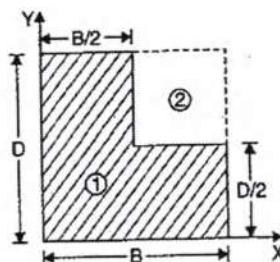

Figure 3

4. A semicircle area is removed from the trapezoid as shown in figure 4. Determine the centroid of the remaining area. [7]

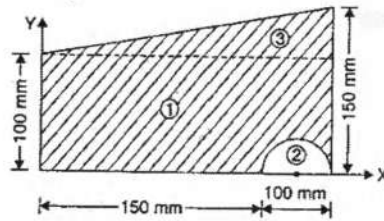

Figure 4

5. Three bars made of copper, zinc and aluminum are of equal length, are rigidly connected at their ends as shown in figure 5. They have cross section area of  $250 \text{ mm}^2$ ,  $275 \text{ mm}^2$  and  $500 \text{ mm}^2$  respectively. If the compound member is subjected to longitudinal pull of 125 kN. Estimate the proportion of load carried on each rod and induced stress. [7]

Take  $E_{\text{Cu}} = 130 \times 10^3 \text{ N/mm}^2$

$E_{\text{Zn}} = 100 \times 10^3 \text{ N/mm}^2$

$E_{\text{Al}} = 80 \times 10^3 \text{ N/mm}^2$

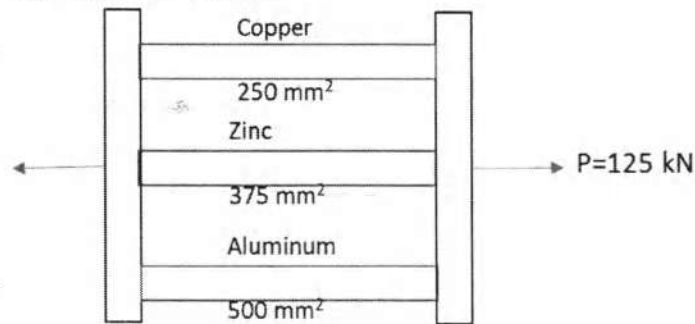

Figure 5

6. For the section shown in figure 6 determine [10]
- moment of inertial about its centroid along (x,y) axis.
  - moment of inertial about new axis which is turned through an angle of  $300^\circ$  anticlockwise to the old axis
  - principal moments of inertia about its centroid.

All dimensions are in cm.

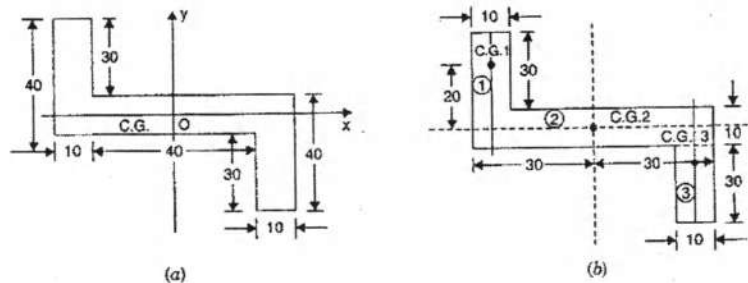

Figure 6

7. The composite bar consisting of steel and aluminum component as shown in figure 7 is connected to two grips at the ends at a temperature of  $60^{\circ}\text{C}$ . Find the stresses in the two rods when the temperature falls to  $20^{\circ}\text{C}$ . (a) if the ends do not yield and (b) if the ends yield by 0.25 mm. [7]

$$\begin{aligned} \text{Take } E_s &= 2 \times 10^5 \text{ N/mm}^2, & E_{al} &= 0.7 \times 10^9 \text{ N/mm}^2 \\ \alpha_s &= 1.17 \times 10^{-5} /^{\circ}\text{C}, & \alpha_{al} &= 2.34 \times 10^{-5} /^{\circ}\text{C} \end{aligned}$$

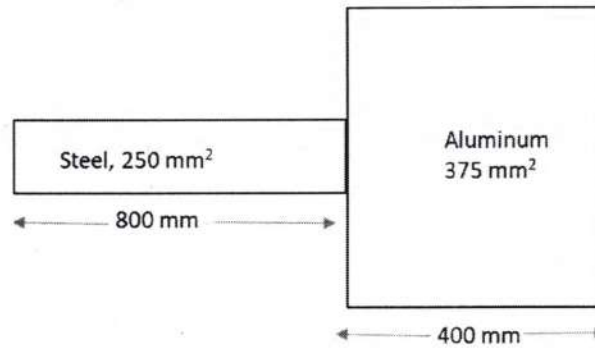

Figure 7

