

KATHMANDU UNIVERSITY
End Semester Examination
September 2024

Marks Scored:

Level : B.E.
Year : I

Course : ENGG 111
Semester : I

Exam Roll No. :

Time: 30 mins.

F. M. : 20

Registration No.:

Date : 26 SEP 2024

SECTION "A"
[20Q. \times 1 = 20 marks]

Choose and encircle the most appropriate answer. Symbols have their usual meanings.

1. The fluid velocity $U = U(x, y, t)$ where x and y represent x -coordinate, and y -coordinate, and t is time. For the mentioned equations, the following conditions are defined.
I) The fluid flows in one direction.
II) The flow represents the unsteady state.
III) The fluid flows in 2 directions.
IV) The flow is in a steady state.

Choose which of these options correctly represents the flow

- a. I and II only
b. I and IV only
c. II and III only
d. The information is not sufficient

2. The fluid in the cylinder is compressed by the force applied to the piston. While doing so, the piston does some work. The work done by such pistons is

- a. Point function
b. path function
c. both point and path function
d. none of these

3. The water meter in your home is an example of

- a. A Pump
b. A Turbine
c. The water meter can sometimes act as a turbine and sometimes as a pump.
d. It is neither a pump nor a turbine

4. Determine the resultant R of the three tension forces acting on the eye bolt. Find the magnitude of R and the angle which R makes with the positive x -axis

- a. 17.43 kN, 26.1°
b. 17.43 kN, 36.1°
c. 16.43 kN, 36.1°
d. 16.43 kN, 26.1°

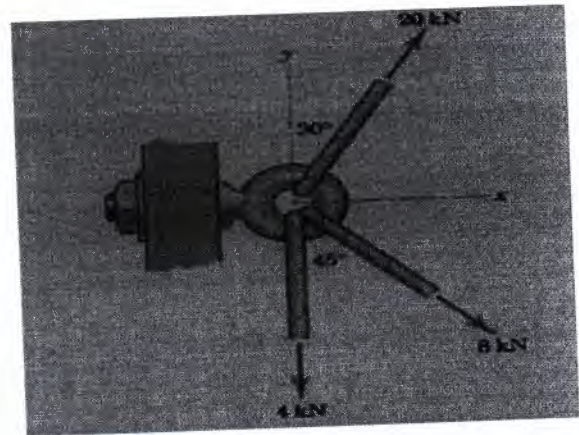

5. Calculate the moment of the 250-N force on the handle of the monkey wrench about the center of the bolt.

- a. 46.4 N-m CW
b. 46.4 N-m CCW
c. 42.4 N-m CCW
d. 42.4 N-m CW

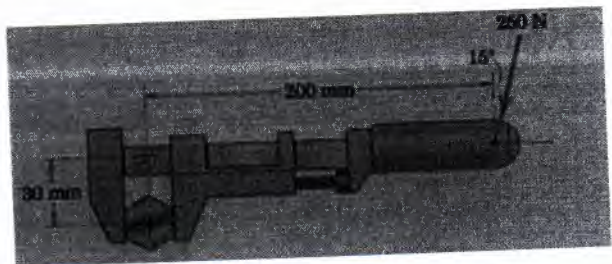

6. The definition of temperature comes from
 a. Zeroth law of thermodynamics
 b. First law of Thermodynamics
 c. Second law of Thermodynamics
 d. Third law of Thermodynamics
7. Water is flowing in a 3 cm diameter garden hose at a rate of 30 L/min. A 20-cm nozzle is attached to the hose which decreases the diameter to 1.2 cm. The magnitude of the acceleration of a fluid particle moving down the centreline of the nozzle is
 a. 14.5 m/s²
 b. 25.4 m/s²
 c. 39.1 m/s²
 d. 47.6 m/s²
8. The rotating part of a turbine is called
 a. Propeller
 b. Runner
 c. Impeller
 d. Scroll
9. A square steel rod 20mm×20mm in section is to carry an axial load (compressive) of 100kN. Calculate the shortening in a length of 10 mm. $E = 2.14 \times 10^8$ kN/m².
 a. 0.0584
 b. 0.0116
 c. 0.0226
 d. 0.0466
10. Total Cylinder volume is
 a. Swept volume + clearance volume
 b. Swept volume – clearance volume
 c. Swept volume
 d. Clearance volume
11. Which of the turbine is generally not used for power generation?
 a. Positive displacement
 b. Reaction
 c. Impulse
 d. Kaplan
12. The SI unit of dynamic viscosity is
 a. m² / s
 b. kg/m-s
 c. m/s²
 d. m³ / s
13. Function of C₃S in the cement is
 a. To provide late strength
 b. To provide early and late setting
 c. To provide volume
 d. To provide early strength
14. Foundation provided for masonry wall in load bearing buildings is
 a. Spread isolated footing
 b. Combined footing
 c. Spread wall footing
 d. Strap footing
15. Brick masonry bond having alternative course of header and stretcher is
 a. Stretcher bond
 b. Header bond
 c. English bond
 d. Flemish bond
16. Main Cable in suspension bridge is in
 a. Compression
 b. Tension
 c. Bending
 d. Shear
17. The number of links in Gunter's chain are:
 a. 100
 b. 10
 c. 16
 d. 66
18. Choose the correct statement from the provided ones.
 a. Whole circle bearing is measured using surveyor's compass.
 b. Invar tape is made of alloy steel consisting 65% Nickel and 35% Steel.
 c. The process of turning the telescope around its horizontal axis is called as plunging.
 d. The process of turning the telescope around its horizontal axis is called as swinging.
19. What is the approximate orbital height of GPS satellites above the Earth's surface?
 a. 10,200 Km
 b. 20,200 Km
 c. 35,800 Km
 d. 42,200 Km
20. In remote sensing, what is typically used as an information carrier?
 a. Sound waves
 b. Electromagnetic radiation
 c. Mechanical waves
 d. Gravitational waves

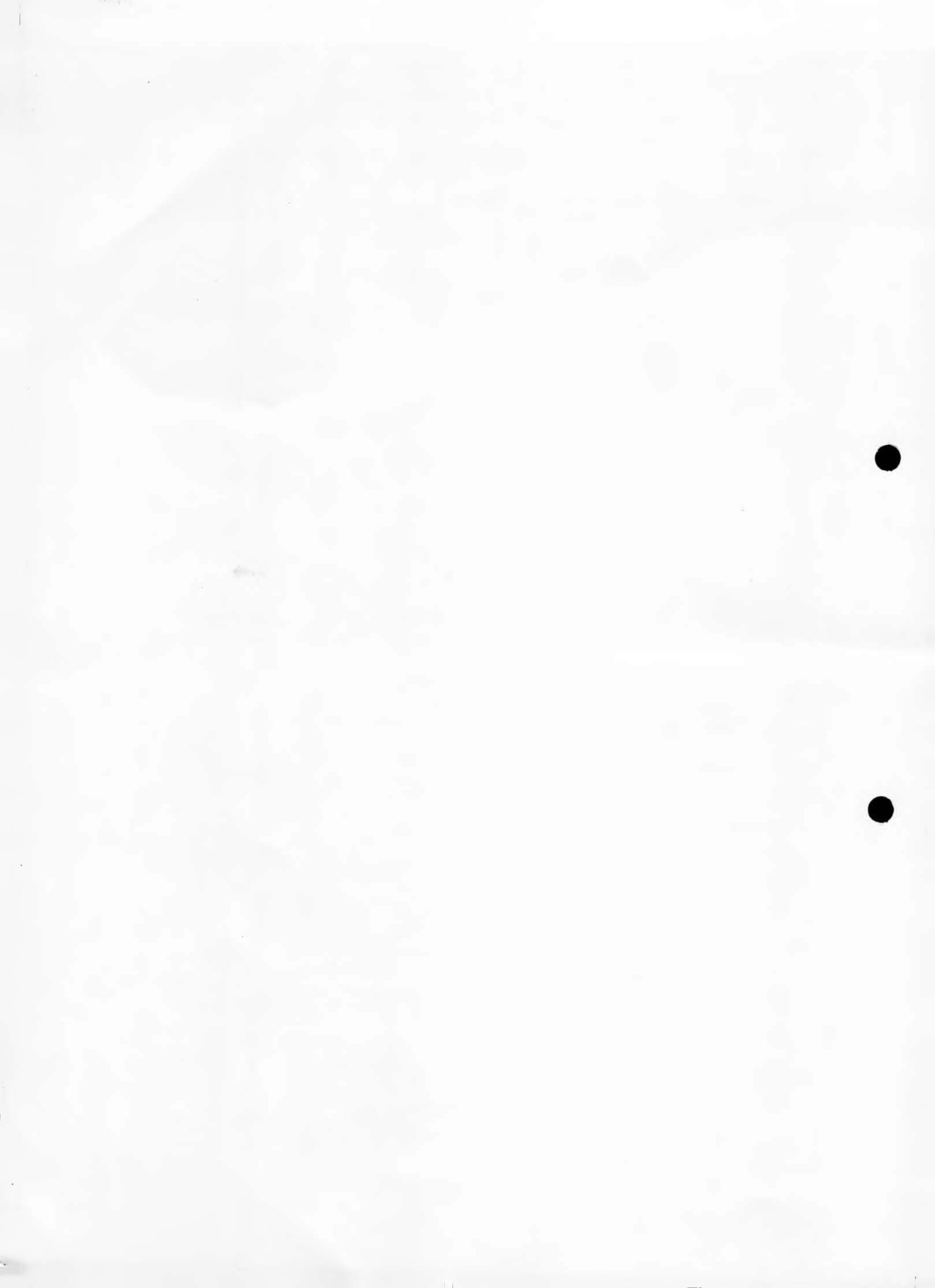

KATHMANDU UNIVERSITY
End Semester Examination
September 2024

Level : B.E.
Year : I
Time : 2 hrs. 30 mins.

26 SEP 2024

Course : ENGG 111
Semester : I
F. M. : 55

Instructions:

- Attempt all the question.
- Assume data suitably if required.
- Use different answer sheets for different Sections B, C and D
- Numbers in the bracket refer to the marks the question carries

SECTION "B"
[33 marks]

1. Determine reactions at A for the beam shown. [6]

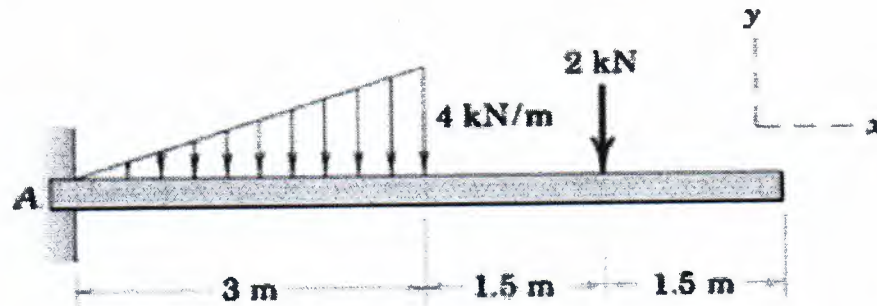

2. Determine the x and y coordinates of the centroid of the shaded area. The triangle is equilateral. [5]

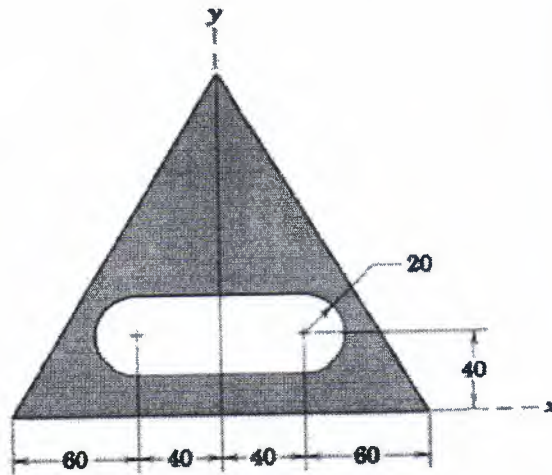

Dimensions in millimeters

Figure for Question No.2

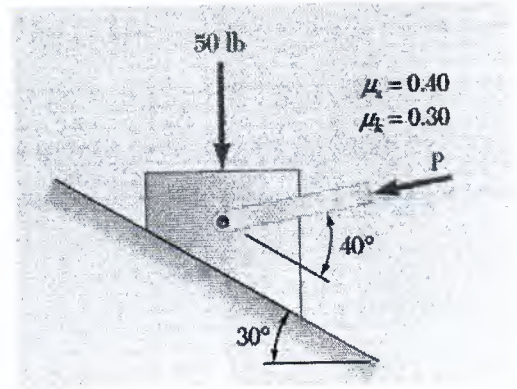

Figure for Question No.3

3. Determine the smallest value of P required to (a) start the block up the incline, (b) keep it moving up. [6]

P.T.O.

4. Briefly explain the concept of internal energy from the first law of thermodynamics. State Kelvin Plank's statement. Explain, does it contradict the first law of thermodynamics? [2+1+2]
5. What does Hook's law state? State the difference in stress-strain curves for ductile and brittle materials (Draw the figure and label them). [1+2]
6. What is a no-slip boundary condition? Define streamline. Consider steady, incompressible, and irrotational flow through a reducer in a horizontal pipe where the diameter is reduced from 20 cm to 10 cm. The pressure in the 20 cm pipe just upstream of the reducer is 150 kPa. The fluid has a vapor pressure of 50 kPa and a specific weight of $5 \text{ kN} / \text{m}^3$. Neglecting frictional effects, find the maximum discharge (in m^3 / s). [1+1+4]
7. Write a major difference between a pump and a turbine with an example of each. [2]

SECTION "C"
[11 marks]

8. For the construction of residential RCC house (building) outside the KU-main gate Dhulikhel Nepal, which type of foundation will you recommend? Explain the features of the recommended foundation with neat sketch. [3]
9. If you are assigned to supervise the brick masonry work in rural village of school building, explain what factors you will consider for the good supervision of construction work. [3]
10. List out the major advantage and disadvantage of the concrete as building material. Explain function of each ingredient of bricks. [1+2=3]
11. Classify dam based on structure? Give one example/Name of Cable Stayed Bridge that is existing in Nepal. [1+1=2]

SECTION "D"
[11 marks]

12. What do you understand by remote sensing? Briefly explain the procedure involved in remote sensing. [1+3]
13. Introduce GPS and explain about the major three components of GPS with proper illustration. [1+3]
14. A traverse is done by three stations A, B and C in clockwise order in the form of an equilateral triangle. If the bearing of AB is $80^{\circ}30'$, find the bearing of other sides. [3]