

KATHMANDU UNIVERSITY
End Semester Examination
June/July, 2023

Marks scored:

Level : B.E.
Year : III

Course : EEEG 309
Semester : II

Exam Roll No. :

Time: 30 mins.

F. M. : 10

Registration No.:

Date : 27 JUN 2023

SECTION "A"

[20Q. \times 0.5 = 10 marks]

Encircle the most appropriate option. Symbols have their usual meaning.

- Which of the following coordinate directly gives the distance of a point from origin?
a. ρ in cylindrical coordinates system
b. r in spherical coordinate system
c. z in cylindrical coordinate system
d. z in cartesian coordinate system
- When two vector fields are perpendicular to each other, their
a. dot product is zero
b. cross product is zero
c. both dot product and cross product are zero
d. none of them are essentially zero
- The work done on moving a charged particle from one point to other in an electric field is given involves computing
a. cross product
b. dot product
c. line integral
d. surface integral
- The gradient of a vector field is.....
a. always a vector
b. always a scalar
c. may be either a scalar or a vector
d. gradient operation does not apply to a scalar
- The divergence of the vector $xa_x + ya_y + za_z$ is equal to.....
a. 0
b. 1
c. 2
d. 3
- Stokes theorem involves.....
a. laplacian
b. gradient
c. divergence
d. curl
- The Gauss divergence theorem converts.....
a. surface to line integral
b. surface to volume integral
c. line to surface integral
d. line to volume integral
- For signal travelling in a lossless transmission line, the radian frequency is 2×10^9 and the corresponding phase velocity is 4×10^6 m/s. The phase constant β is equal to:
a. 500
b. 1000
c. 50
d. 0.002
- A general electric connection differs from a transmission line as.....
a. the velocity in transmission line is very high
b. the loss in transmission line is very low
c. the length of conductors in transmission line is comparable to wavelength
d. the length of conductors in transmission line is larger compared to wavelength

KATHMANDU UNIVERSITY
End Semester Examination
June/July, 2023

27 JUN 2023

Level : B. E.
Year : III
Time : 2 hrs. 30 mins.

Course : EEG 309
Semester : II
F.M. : 40

SECTION "B"

[5Q. × 8 = 40 marks]

Attempt *ANY FIVE* questions. Use constants and relations provided if needed. Assume suitable values for missing parameters if any. **Smith chart will be provided.**

1. a. Consider the vector defined as $A = 3a_x + 4a_y + 5a_z$ at the point $P(3, 4, 5)$ in rectangular coordinate system. Convert it to the spherical co-ordinate system at the point. What comment can you make looking at the result? [3]
- b. What do you understand by the term '*field*'? Explain with example of electromagnetic field. [2]
- c. Two point charges $Q_1 = 8\pi\epsilon_0 C$ and $Q_2 = 4\pi\epsilon_0 C$ are located at points $P_1(-1, 0, 0)$ and $P_2(1, 0, 0)$. Considering that the medium is air, find E at $P_3(0, 0, 1)$. Also compute the magnitude and direction of the field. [3]
2. a. State and explain the Gauss' law and hence the concept of electric flux and flux density. [3]
- b. A 20 nC point charge is at the origin in free space. Calculate the scalar electric potential at point $Q(-2, 3, -1)$ assuming that zero reference is at i) infinity ii) point $R(6, 5, 4)$. [3]
- c. Explain the relationship to compute electric field intensity E from scalar potential V . [2]
3. a. Explain the nature of *uniform plane wave*. [1]
- b. Let a uniform plane wave propagating in a perfect dielectric at a velocity of 1.4×10^8 m/s is represented by field expressions $E(z, t) = 1800 \cos(10^7\pi t - \beta z) a_x$ V/m and $H(z, t) = 3.8 \cos(10^7\pi t - \beta z) a_y$ A/m. Find the following parameters for the wave: i) β , ii) λ , iii) η , iv) μ_r , v) ϵ_r . [4]
- c. Derive the expression for electric and magnetic fields for a uniform plane wave propagating in a perfect dielectric medium. [3]
4. a. When a transmission line is terminated by a load not equal to the characteristic impedance, reflections occur. Derive the expressions for the reflection and transmission coefficients in such case. [3]
- b. In the figure shown, the terminating load on the $Z_0 = 100 \Omega$ line is $Z_L = 50 - j10 \Omega$. The frequency used is 500 MHz and velocity is equal to that of light. Using the provided Smith Chart, find reflection coefficient Γ and standing wave ratio s . Also find the parameters of a short-circuited stub (shortest distance d and the shortest length d_1) that will provide a perfect match on the main line. [5]

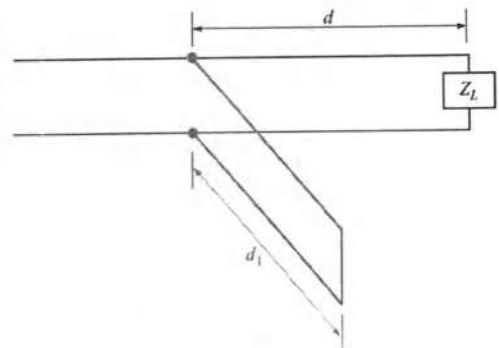

5. a. Determine the primary constants (R, L, C and G) on the transmission line when the measurement on the line at 1 KHz gave the following results: $z_0 = 710 \angle -16^\circ$, $\alpha = 0.01 \text{ neper/m}$, $\beta = 0.035 \text{ rad/m}$. [4]
- b. Starting from the general transmission line equation in real time instantaneous form, obtain the phasor form of the equation and its solutions for phasor voltage and currents, and also derive the expression for characteristic impedance. [4]
6. a. A parallel plate waveguide filled with a material having dielectric constant $\epsilon_r' = 2.5$ has plate separation of 1.2 cm. Determine the maximum operating frequency such that only the TEM mode will propagate. Also find the range of frequencies that support up to TE_1 and TM_1 ($m=1$) modes. [3]
- b. How does a wave guide differ from a transmission line? Write short note on modes supported by a wave guide. [3]
- c. Introduce how a quarter wave transformer can be used to match a transmission line to a load. [2]

Some useful constants and relations:

$$\epsilon_0 = 8.85 \times 10^{-12} \text{ F/m}$$

$$\mu_0 = 4\pi \times 10^{-7} \text{ H/m}$$

Relation between spherical and Cartesian coordinates

$$r = \sqrt{x^2 + y^2 + z^2}$$

$$\theta = \cos^{-1} \frac{z}{\sqrt{x^2 + y^2 + z^2}}$$

$$\phi = \tan^{-1} \frac{y}{x}$$

	\mathbf{a}_r	\mathbf{a}_θ	\mathbf{a}_ϕ
\mathbf{a}_x	$\sin \theta \cos \phi$	$\cos \theta \cos \phi$	$-\sin \phi$
\mathbf{a}_y	$\sin \theta \sin \phi$	$\cos \theta \sin \phi$	$\cos \phi$
\mathbf{a}_z	$\cos \theta$	$-\sin \theta$	0

For a transmission line:

$$Z_0 = \sqrt{\frac{R + j\omega L}{G + j\omega C}}$$

$$\sqrt{(R + j\omega L)(G + j\omega C)} = \sqrt{ZY} = \alpha + j\beta$$

For parallel plate waveguides

$$\omega_{cm} = \frac{m\pi c}{nd}$$

$$\beta_m = \frac{n\omega}{c} \sqrt{1 - \left(\frac{\omega_{cm}}{\omega}\right)^2}$$

$$\lambda_{cm} = \frac{2\pi c}{\omega_{cm}} = \frac{2nd}{m}$$

27 JUN 2023

The Complete Smith Chart

Black Magic Design

