

KATHMANDU UNIVERSITY  
End Semester Examination [C]  
June, 2018

JUN 14 2018

Level : B.E.  
Year : III  
Time : 2hrs. 30 mins.

Course : COEG 304  
Semester : I  
F. M. : 55

SECTION "B"

[5 Q. × 11 = 55 marks]

Attempt *ANY FIVE* questions.

1. a. Differentiate open loop and closed loop control system with examples. [4]
- b. The closed loop transfer function of a first order system is  $\frac{C(S)}{R(S)} = \frac{k}{S+a+k}$  and the final steady state value of response due to a unit step input is 0.86. The time constant is found to be 0.2sec .Determine the value of k, a and the time domain response of the system. [3]
- c. The open loop transfer function of a unity feedback control system is given by  $G(S) = \frac{K}{s(1+sT)}$ . By what factor the amplifier gain 'K' should be multiplied so that the damping ratio is increased from 0.3 to 0.9. [4]
2. a. Obtain the transfer function  $\frac{X_2(S)}{F(S)}$  for the mechanical system shown in figure below. [6]

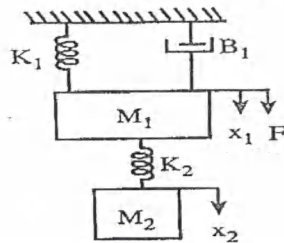

- b. Explain the modeling of a capacitance of liquid level system and obtain the transfer function if small deviation of outflow rate and inflow rate from its steady state value is considered as output and input of the system respectively. [5]
3. a. Reduce the block diagram and determine the transfer function,  $\frac{Y(S)}{R(S)}$  of the figure given below. [6]

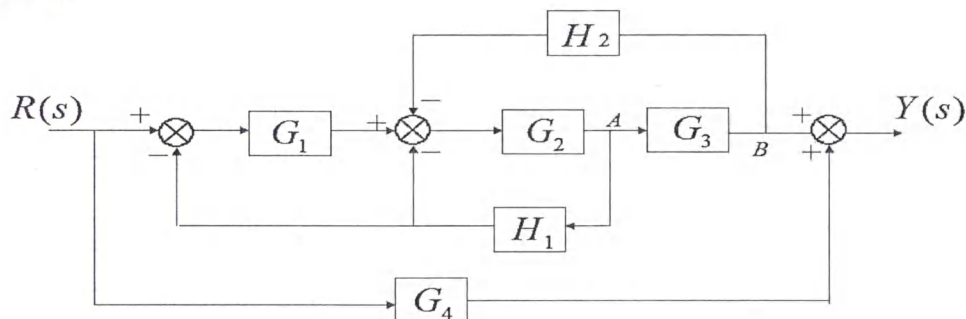

- b. Explain the different types of pressure sensor in brief. [5]

4. a. Determine the stability of the unity feedback control system whose open loop transfer function is  $G(S) = \frac{KS^3}{S^4+S^2+S+1}$  [4]
- b. The open loop transfer function of a system with a unity feedback is given by  $G(S) = \frac{K}{S(S+3)}$ . The specification is to meet  $M_p=15\%$  and  $K_v=6\text{sec}^{-1}$ . Can a value of K meet both the criteria, justify. [4]
- c. A strain gauge is bonded to a beam of 0.1 m long and has a cross-sectional area of  $4\text{ cm}^2$ . The modulus of elasticity is  $207\text{ GN/m}^2$ . The strain gauge has an unstrained resistance of  $240\ \Omega$  and a gauge factor of 2.2. When a load is applied, the resistance of gauge changes by  $0.013\ \Omega$ . Calculate the change in length of the steel beam and the amount of force applied to the beam. [3]
5. a. A closed loop control system with unity feedback is shown in figure below. By using PD control the damping ratio is to be made 0.7. Determine the value of peak time with and without PD control for unit step input. Give the reason of difference in the peak time. [7]

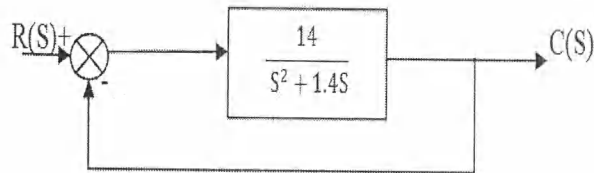

- b. The open loop transfer function of a unity feedback system is  $G(S) = \frac{100}{S(S+1)(S+10)}$ . Determine the static error constants for the given system. Also determine the steady state error for  $r(t) = P_0 + P_0 t + P_0 \frac{t^2}{2}$  input. [4]
6. a. Draw a PLC ladder diagram for automatic heating and cooling system which includes following condition: [6]
- The heater will be ON when the power switch is pressed, door is closed and the temperature is below the limit.
  - The fan will be ON when the heater is ON or temperature is above the limit and the door is closed.
  - The light will be ON if the light switch is ON or whenever the door is opened.
- b. Write short notes on: [2.5+2.5]
- Flow sensor
  - Application of op-amp in Electrocardiogram