

KATHMANDU UNIVERSITY
End Semester Examination
February/March, 2019

FEB 20 2019

Level : B.E.
Year : III
Time : 2 hrs. 30 mins.

Course : COEG 304
Semester: I
F.M. : 55

SECTION "B"

[5 Q × 11 = 55 marks]

Attempt ANY FIVE questions. Assume missing parameters suitably.

1.

a. Derive the unit step response of a second order system for overdamped case and determine
i) unit step response $y(t)$ ii) steady state error at infinity $e(\infty)$ [7]

b. Calculate the inverse Laplace transform of the differential equation. [4]

$$\frac{d^2y(t)}{dt^2} + 3 \frac{dy(t)}{dt} + 2y(t) = 5u(t), \text{ where } u(t) \text{ is the unit step function.}$$

The initial conditions are $y(0) = -1$ & $y'(0) = 2$ at $t = 0$.

2.

a. Reduce the block diagram and determine the transfer function, $\frac{Y(S)}{R(S)}$ of the figure given below. [7]

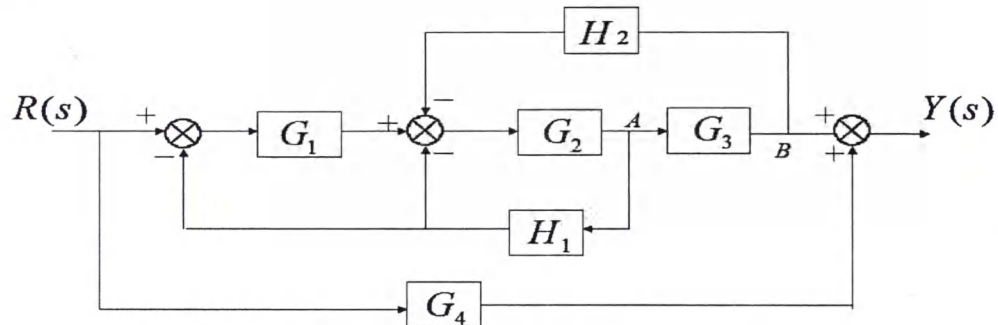

b. Determine the stability of the closed loop transfer function using Routh Hurwitz stability criterion. [4]

$$T(S) = \frac{K}{S^3 + 18S^2 + 77S + K}$$

3.

a. Obtain the transfer function $\frac{X_2(S)}{F(S)}$ for the mechanical system shown in figure below. [7]

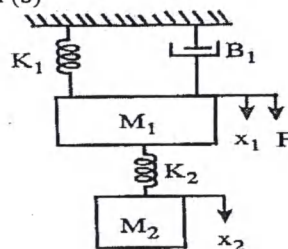

b. The open loop transfer function of a system with a unity feedback is given by $G(S) = \frac{K}{S(S+3)}$. The specification is to meet $M_p = 15\%$ and $K_v = 6 \text{ sec}^{-1}$. Can a value of K meet both the criteria, justify. [4]

- 4.
- Explain the block diagram of analog signal conditioning in brief. [7]
 - A temperature sensor has a measurement range of -10° to 150°C . The output range is -1.5 to $+5\text{mv}$. It has a resolution of 0.1°C . [4]
 - Determine the number of bits in ADC?
 - What is the digital reading of the ADC when the output of the sensor is $+5\text{ mv}$.
- 5.
- Consider a house in a cold climate which is to be maintained near a desired temperature by circulating hot water through a heat exchanger. Explain the closed loop control system that is well suited for this condition. [6]
 - The open loop transfer function of a unity feedback system is $G(S)=\frac{100}{s(s+1)(s+10)}$. Determine the static error constants for the given system. Also determine the steady state error for $r(t)=P_0 + P_0 t + P_0 \frac{t^2}{2}$ input. [6]
- 6.
- Draw the PLC ladder diagram for the infrared sensing system in which when someone enters the infrared sensing field, opening motor starts working to open the door automatically till the door touches the opening limit switch. If the door touches the opening limit switch for 7 sec and nobody enters the sensing field, the closing motor starts working to close the door automatically till the closing limit switch touched together. And stops the closing action if someone enters the sensing field during the door closing process. [6]
 - Write short notes on (ANY TWO): [2.5 × 2 = 5]
 - Transient response of a critically damped system.
 - Steady state response of a system with P controller.
 - Dynamic and static characteristics of a sensor.

FEB 20 2019

KATHMANDU UNIVERSITY
End-Semester Examination
February/March, 2019

Marks Scored:

Level : B.E.

Year : III

Course : COEG 304

Semester: I

Exam Roll No.:

Time: 30 mins.

F.M. : 20

Registration No.:

Date FEB 20 2019

SECTION "A"
[20 Q × 1=20 marks]

Choose and encircle the most appropriate option.

- Which of the controller will eliminate the steady state error of the system?
 a) a proportional integral controller b) a proportional controller
 c) an integral controller d) a derivative control
- The transfer function of a system given by $TF = \frac{100}{s^2 + 20s + 100}$. The damping nature of the system is _____.
 a) over damped b) critically damped
 c) under damped d) undamped
- The unit step error coefficient of a system $G(S) = \frac{1}{(s+6)(s+1)}$ with unity feedback is _____.
 a) 1/7 b) ∞ c) 1/8 d) 1/6
- For a unity feedback control system open loop transfer function is $G(s) = \frac{10}{s(s+1)}$ then its velocity error constant is _____.
 a) 10 b) 10.5 c) 10.8 d) ∞
- Determine the value of 'a' such that the damping ratio of a closed loop control system having transfer function, $\frac{C(S)}{R(S)} = \frac{16}{s^2 + (0.8+16a)s + 16}$ is 0.5.
 a) 0.28 b) 0.2 c) 0.25 d) 0.5
- The transfer function of a closed loop control system is $\frac{C(S)}{R(S)} = \frac{16}{s^2 + 4s + 16}$ then determine the value of rise time.
 a) 1.5s b) 0.607s c) 0.65s d) 0.605s
- Obtain the inverse Laplace transform of $\frac{1}{s^2 + 4s + 8}$
 a) $0.5e^{-2t}\sin 2t$ b) $0.5e^{-2t}\cos 2t$ c) $0.5e^{-t}\sin 2t$ d) $e^{-2t}\sin 2t$
- Which of the following process of PLC has highest time allocation?
 a) input scan b) output scan c) program scan d) monitoring
- A closed loop control system has the characteristic equation, $s^3 + 4.5s^2 + 3.5s + 1.5 = 0$. Using Routh Herwith criterion, the characteristics of the system is _____.
 a) marginally stable b) critically stable
 c) stable d) unstable

