

10. A closed loop system is stable if all the poles of the system lies at _____.
- Left side of imaginary axis.
 - Right side of the imaginary axis.
 - Imaginary axis.
 - One on left and one on right of imaginary axis.

11. The steady-state error for the system in figure 3 below is _____ if $T(s) = 5/(s^2 + 7s + 10)$ and the input is a unit step.
- $e(\infty) = 1.5$ $e(\infty) = 1$
 - $e(\infty) = 0.5$ $e(\infty) = 0.25$

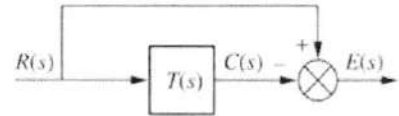
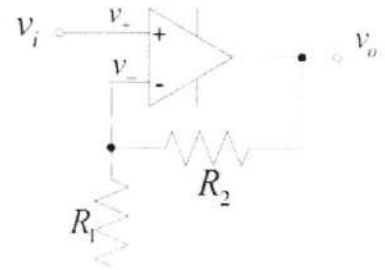

Figure 3

12. The gain of the system in figure below is _____.
Given $R_1 = 1 \Omega$ and $R_2 = 2 \Omega$.

- 1 2
- 3 4



13. High-pass, low-pass and notch filters are used to _____.
- eliminate unwanted noise. shift the frequency.
 - addition of signals divide the voltage.
14. $(0.625)_{10} = (?)_2$
- 0.111 0.101 0.011 0.110

15. Limit switch is an example of _____.
- current switch voltage switch
 - temperature switch proximity switch

Fill in the blanks (maximum of two words).

16. A proportional controller the output (also called the actuating signal) is directly proportional to the _____.
17. Ideal op-amps have _____ voltage gain.
18. The _____ controller is used to eliminate the steady state error.
19. PLCs, or programmable logic controllers, are computers designed to operate under _____ industrial environments and _____ complex processes.
20. _____ sensor can be used to sense level without any physical contact.

KATHMANDU UNIVERSITY
End Semester Examination [C]
December, 2024

Level : B.E.
Year : III
Time : 2 hrs. 30mins.

16 DEC 2024

Course : COEG 304
Semester : I
F. M. : 40

SECTION "B"

[5 Q. × 8 = 40 marks]

Attempt ANY FIVE questions. Assume any suitable data if necessary.

1. a. Simplify the block diagram to obtain the transfer function, $C(S)/R(S)$, for the system shown in figure 4. [4]

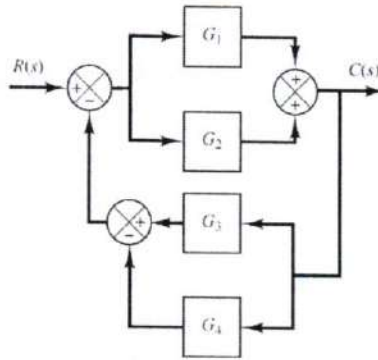

Figure 4. Block diagram of a system

- b. Find the transfer function, $G(s) = X_1(s)/F(s)$, or the translational mechanical system shown in figure 5. [4]

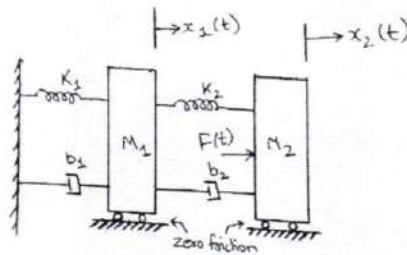

Figure 5: Mechanical system

2. a. Discuss the importance of signal conditioning in reducing noise in a control system. Explain how different types of filters (low-pass, high-pass, band-pass) are used to eliminate unwanted noise from the signal. Provide examples of scenarios where each type of filter would be appropriate. [4]
- b. Derive and explain the time response characteristics of a first order system to a unit step input. Also, show that rise time is equivalent to 2.22 times the time constant. [4]

P.T.O.

3.

- a. For the system with characteristic equation as below, determine if the system is stable or not. Also, explain what does the system imply if a row of zeros appear in Routh Array. [4]

$$T(s) = s^5 + 2s^4 + 2s^3 + 4s^2 + s + 2$$

- b. Use an inverting amplifier, an integrator, and a summing amplifier to develop an output voltage given by: [4]

$$V_{out} = 10 V_m + 4 \int V_m dt$$

4.

- a. Design and describe a complete data acquisition system (DAQ) for monitoring and controlling the environmental conditions in a greenhouse. [4]
- b. Identify the types of sensors required to monitor parameters such as temperature, humidity, soil moisture, and light intensity for the system of question 4 (a). Explain the signal conditioning techniques needed for each sensor to ensure accurate and reliable data acquisition. [4]

5.

- a. Explain the working principle of Linear Voltage Differential Transformer (LVDT) with appropriate figure. [2]
- b. For an automatic water tank system as shown in Figure 6, there are two level sensors, L_{up} and L_{down} and a pump. For this automatic water tank system, pump is 'on' if water is below the lower level and pump is 'off' if water is above the higher level. When water is between top and bottom level, the pump should be on/off depending upon the previous state of the pump. Which means if the previous state of pump is on then it should be turned on and if the previous state is off then the pump should be kept off. [6]

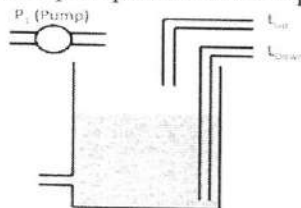

Figure 6: Water Tank

- i. Develop a Discrete logic for the controller of the system.
- ii. Implement the Discrete logic of the controller in PLC. Draw the ladder diagram for the controller program.

6.

- a. Design and draw a block diagram for closed-loop speed control system for an automobile. Explain why closed loop system is better for accurate control than an open loop system. [4]
- b. Write short notes on any two of the following statements. [4]
- i. Different types of temperature sensor.
 - ii. The derivative or differential controller is never used alone.
 - iii. Working of optical encoder.