

KATHMANDU UNIVERSITY
End Semester Examination
July/August 2024

Level : B.Arch.
Year : II
Time : 2 hrs. 30mins.

11 AUG 2024

Course : CIEG 231
Semester : I
F. M. : 40

SECTION "B"
[40 marks]

Attempt *ALL* questions.

1. State & prove Varignon's Theorem. Derive the equations of motion of particle of a rigid body when acceleration is given as a function of time. [2+2]
2. A semi-circular area is removed from a trapezium as shown in Figure 1. Determine the centroid of the remaining area (shown hatched). All dimensions are in mm. [5]

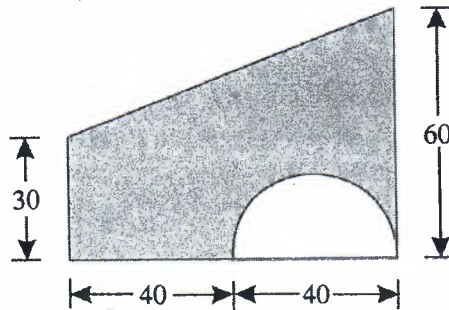

Figure 1

3. Find the second moment of the section shown in Figure 2 having a semi-circular hole of radius 20mm about its Centroidal axis, both X & Y axes are required. All dimensions are in mm. Take ED & EA as axis of reference. [7]

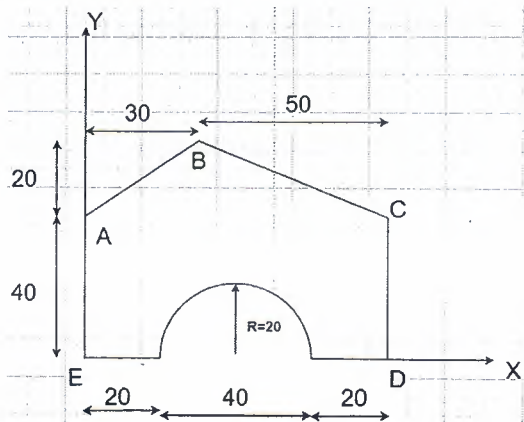

Figure 2

P.T.O.

4. A light string ABCDE whose extremity A is fixed, has weights W_1 and W_2 attached to it at B and C. It passes round a small smooth peg at D carrying a weight of 300 N at the free end E as shown in Figure 3. If in the equilibrium position, BC is horizontal and AB and CD make 150° and 120° with BC, find
- Tensions in the portion AB, BC and CD of the string and
 - Magnitudes of W_1 and W_2
- [2+2]

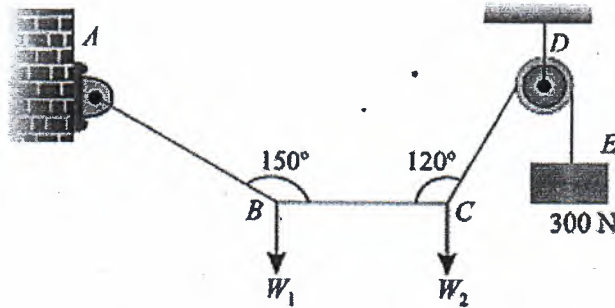

Figure 3

OR

Figure 4 shows the system of coplanar forces acting on the flat plate OAED. Determine:

- The resultant
 - Position of the resultant
- [2+2]

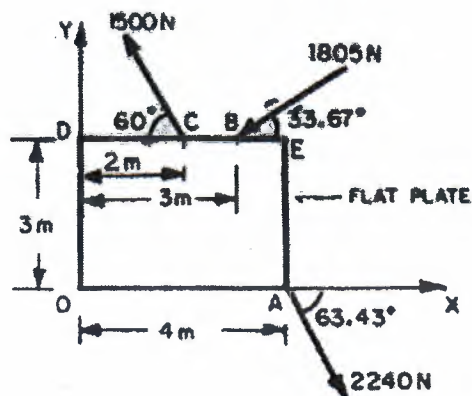

Figure 4

5. Derive the relationship between load, shear force and bending moment. [4]