

KATHMANDU UNIVERSITY
End Semester Examination
June/July, 2023

Marks Scored:

Level : B.E.
Year : II

Course : CIEG 208
Semester : II
F. M. : 10

Exam Roll No. : _____ Time: 30 mins.

Date **10 JUL 2023**

Registration No.: _____

SECTION "A"
[20 Q. × 0.5 = 10 marks]

Encircle the most appropriate answer.

1. A prismatic beam is shown in the figure 1.
Consider the following statements:

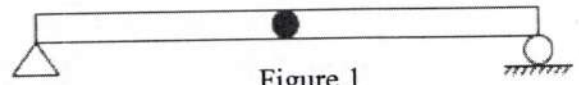

- I) The structure is unstable
II) The bending moment is zero at support and internal hinge
III) It is a mechanism
IV) It is statically indeterminate

Which of the statements are **CORRECT**?

- a. I, II and III b. I, II, III and IV c. I and II d. III and IV
2. During tensile testing of a specimen using a UTM, the parameters actually measured include-
- a. True stress and true strain
b. Poisson's ratio and young's modulus
c. Engineering stress and Engineering strain
d. Load and elongation

3. The total (both external and internal) degrees of indeterminacy of the structure shown in the figure 2 is
- a. 9 b. 10 c. 12 d. 13

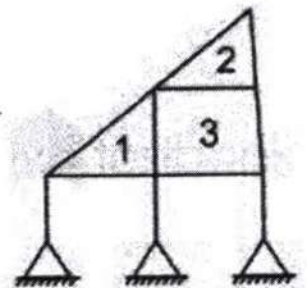

Figure 2

4. A cross – section bar of area 700 mm² is subjected to an axial load as shown in the figure 3. What is the value of stress (MPa) in the section PQ?
- a. 30
b. 90
c. 40
d. 50

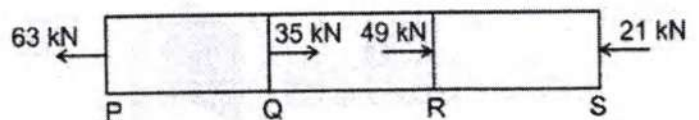

Figure 3

5. Mohr's circle is often used to calculate
- Principle strain
 - Principle stress
 - Modulus of rigidity
 - Beam stiffness
6. If the principal stresses in a plane stress problem, are $\sigma_1 = 100 \text{ MPa}$ and $\sigma_2 = 40 \text{ MPa}$, the magnitude of the maximum shear stress (in MPa) will be
- 50
 - 20
 - 60
 - 30
7. A hollow circular section having 8 cm outer diameter and 6 cm inner diameter, the radius of gyration will be
- 2.5 cm
 - 1.5 cm
 - 2.0 cm
 - 3 cm
8. What is the stress developed in bending a 10 mm diameter steel rod of $E = 2 \times 10^5 \text{ N/mm}^2$ to 1000 mm radius of curvature?
- 500 N/mm²
 - 2000 N/mm²
 - 1000 N/mm²
 - 981 N/mm²
9. According to pure bending theory, which of the following claims factually **INCORRECT**?
- Beam material is isotropic
 - Beam material is homogenous
 - Permissible stresses are under elastic limit
 - Every layer has a different center of curvature
10. A cantilever beam of length L, with uniform cross section and flexural rigidity, EI is loaded uniformly by a vertical load of w kN/m. the maximum vertical deflection of the beam is given by:
- $\frac{wL^4}{16EI}$
 - $\frac{wL^4}{8EI}$
 - $\frac{wL^4}{4EI}$
 - $\frac{wL^4}{24EI}$
11. An inverted T- section is subjected to a shear force F. the maximum shear stress will occur at:
- Top of the section
 - Junction of web and flange
 - Neutral axis of the section
 - Bottom of the section
12. For hollow shaft of external diameter and internal diameter 10 cm and 5 cm respectively, the ratio of polar moment of inertia to its radius will be approximately;
- 184 cm
 - 275 cm
 - 368 cm
 - 536 cm
13. Pure torsion of shaft produces:
- Longitudinal normal stress in shaft
 - Only direct shear stress in the transverse section of the shaft
 - Circumferential shear stress on a surface element of shaft
 - A longitudinal shear stress and a Circumferential shear stress on a surface element of shaft
14. A thin cylindrical shell of diameter 'd', wall thickness 't' is subjected to an internal fluid pressure 'p'. If E is the modulus of elasticity and ' θ ' is the Poisson's ratio of the material, the volumetric strain of the cylinder is given by
- $\frac{pd}{4tE} (5 - 4\theta)$
 - $\frac{pd}{4tE} (4 - 5\theta)$
 - $\frac{pd}{2tE} (5 - 4\theta)$
 - $\frac{pd}{2tE} (4 - 5\theta)$

10 JUL 2023

15. A boiler of 1.6 m diameter is made of a 20 mm thick plate. What will be the permissible steam pressure in the boiler when the maximum tensile stress in the plate must **NOT** exceed 80 MPa?
a. 2 GPa b. 20 MPa c. 2 MPa d. 20 GPa
16. The buckling load for a given material depends upon:
a. Slenderness ratio and cross sectional area
b. Slenderness ratio and modulus of elasticity
c. Poisson's ratio and modulus of elasticity
d. Poisson's ratio and Slenderness ratio
17. What is the relationship between Young's modulus E , modulus of rigidity C , and bulk modulus K ?
a. $E = 9KC / (3K + C)$ b. $E = 9KC / (9K + C)$
c. $E = 3KC / (3K + C)$ d. $E = 3KC / (9K + C)$
18. A compressive member always tends to buckle in the direction of
a. Axis of load b. minimum cross-section
c. Least radius of gyration d. perpendicular to the axis of load
19. In a beam of I- section the maximum shear forces is carried by
a. The upper flange b. The web of the beam
c. The lower flange d. Both a and c
20. If a piece of material neither expands nor contracts in volume when subjected to stresses, then the Poisson's ratio must be
a. 0.15 b. 0.25 c. 0.33 d. 0.5

10 JUL 2023

Course : CIEG 208
Semester : II
F. M. : 40

Level : B.E.
Year : II
Time : 2 hrs. 30 mins.

SECTION "B"

Attempt **ALL** Questions. Assume suitable data if necessary.

1. Explain the principal plane and principal stress taking reference of an inclined plane of a body subjected to uniaxial forces. A composite bar consisting of a steel rod and copper rod connected to each other at the ends as shown in Figure 1. The area of steel bar is 50 mm^2 . The copper bar has an area of 50 mm^2 for half the length and 100 mm^2 for the remaining length. If the temperature of the assembly is raised by 30° C , find the stresses in the rods. [2+4=6]

Take $E_s = 2 \times 10^5 \text{ N/mm}^2$, $E_c = 1 \times 10^5 \text{ N/mm}^2$, $\alpha_s = 1.2 \times 10^{-5} / ^\circ\text{C}$, $\alpha_c = 1.5 \times 10^{-5} / ^\circ\text{C}$.

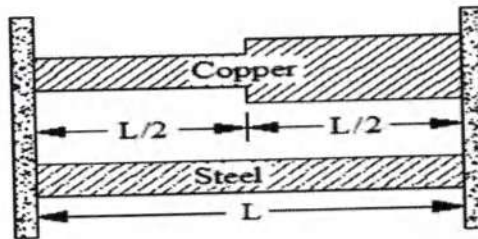

Figure 1

2. Determine the orientation of principal axes and principal moment of inertia about centroidal axes of the composite section shown in Figure 2. [6]

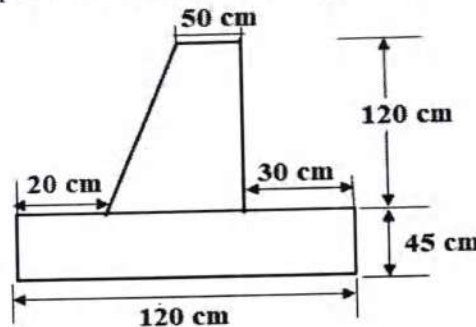

Figure 2

3. A shaft of 80mm diameter is having a concentric bore of diameter 40mm up to half the length as shown in Figure 3. Find the total angle of twist for the loading shown. [5]
Take $G = 80 \text{ kN/mm}^2$.

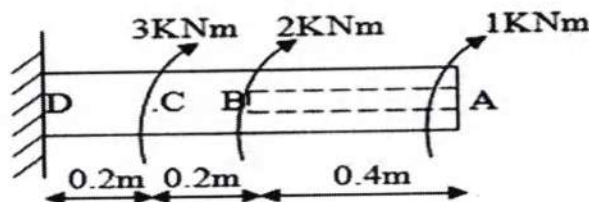

Figure 3

4. A beam with overhanging ends loaded by the three concentrated forces shown in Figure 4. The beam is simply supported and of inverted T – type cross-section as shown. The material is cast iron having an allowable working stress in tension of 70 MPa and in compression of 300 MPa. Determine the maximum allowable value of P. [6]

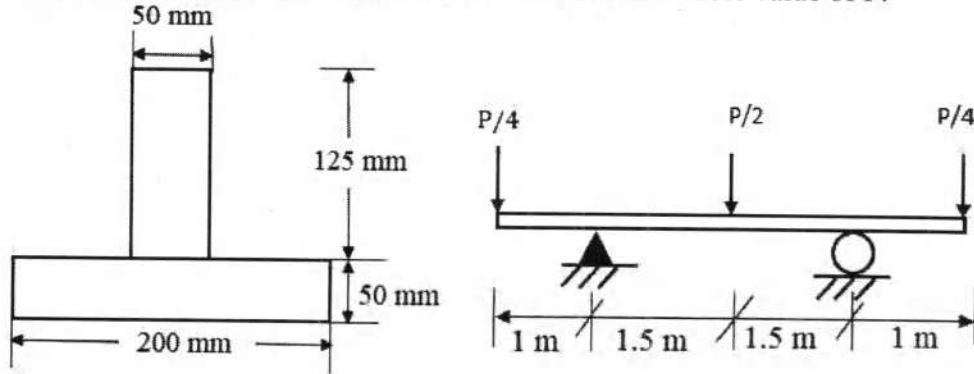

Figure 4

5. A cylindrical shell is 1 m diameter and 6 m long. It is subjected to 40 kg/cm² internal pressure. If the minimum principal stress is not to exceed 750 kg/cm², find the thickness of the shell. Assume $E = 2 \times 10^6$ kg/cm² and Poisson's ratio = 0.25. Find the change in dimensions of the shell and the maximum intensity of shear stress developed. [5]
6. A simply supported beam of length 5 m is subjected to a uniformly distributed load of 25 kN/m over the whole span and deflects 15 mm at the Centre. Determine the crippling load and also safe load taking safety as 2.5, when this beam is used as a column with the following conditions: [5]
- One end of the column is fixed and the other end is free
 - One end of the column is fixed and the other end is hinged
7. Draw axial force, shear force and bending moment diagrams for the frame shown in Figure 5 indicating the principal numerical values at salient point. [7]

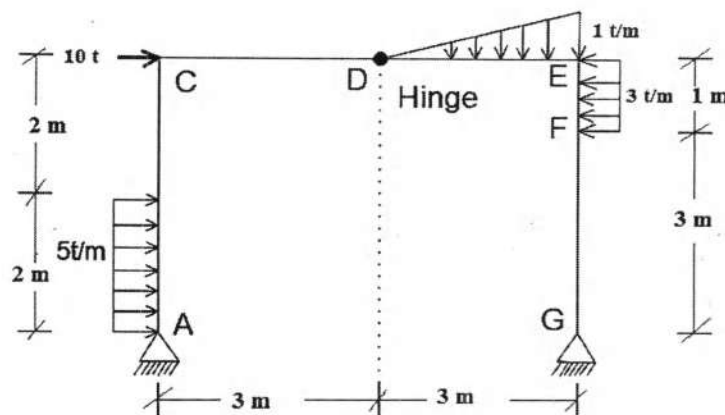

Figure 5