

Level : B.E.

Course : CIEG 203

Year : II

Semester : I

Exam Roll No. :

Time: 30 mins.

F. M. : 10

Registration No.:

Date 07 DEC 2023

SECTION "A"

[20 Q. × 0.5 = 10 marks]

Encircle the most appropriate option.

- Two forces P (900 N & acting at angle of 30 degrees with x-axis) and Q (600 N & acting at angle of 75 degree with x-axis) acting at a point O, its resultant in magnitude and direction with respect to x-axis is
 - 1391 N and 17.8 degree
 - 1391 N and 47.8 degree
 - 391 N and 62.77 degree
 - 1391 N and 27.23 degree
- Which is not the fundamental principle of mechanics?
 - Parallelogram law of addition of forces
 - Principle of transmissibility
 - Newton's forth laws of motion
 - Newton's law of gravitation
- If the two forces P and Q are equal and are acting at perpendicular to each other, then
 - Resultant is $P\sqrt{2}$
 - Resultant is $2\sqrt{P}$
 - Resultant is $2P$ and $2Q$
 - Resultant is $2\sqrt{Q}$
- Moment of a force about an axis is
 - A vector quantity
 - A scalar quantity
 - Can be determined by Varignon's theorem
 - Can be determined by Lami's Theorem
- Center of gravity cannot be determined by
 - Geometrical construction
 - Graphical method
 - Moments method
 - Differentiation method
- CG of the Given Figure (parabolic spandrel) is
 - $\bar{x} = \frac{a}{4}$ and $\bar{y} = \frac{3h}{10}$
 - $\bar{x} = \frac{3a}{4}$ and $\bar{y} = \frac{3h}{10}$
 - $\bar{x} = \frac{3x}{4}$ and $\bar{y} = \frac{3y}{10}$
 - $\bar{x} = \frac{x}{4}$ and $\bar{y} = \frac{3y}{10}$
- For friction the **INCORRECT** statement is
 - Dry friction is called Coulombs friction
 - Fluid friction is known was viscosity
 - Coefficient of static friction is generally more than coefficient of kinetic friction
 - The force of dynamic friction remains increases slightly with the increase in speed

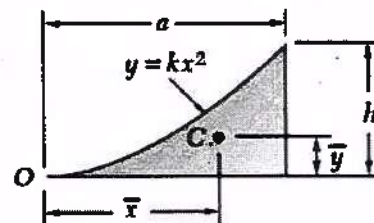

8. Characteristics of friction is
- Acts in the direction in which motion is intended
 - It is passive force
 - It is not self-adjusting force
 - Friction force is maximum at the peak motion
9. For a circular area having origin at its center, if the radius is 20 meter, then
- Moment of inertia about X-axis and Y-axis is same and is 251328 m^4
 - Moment of inertia about X-axis and Y-axis is different and is 251328 m^4 and 125664 m^4 respectively.
 - Polar moment of inertia is half of the MOI about X-axis
 - Polar moment of inertia is twice of the MOI about X-axis

10. For a triangle with base "b" and height "h" the correct statement is

- MOI about x- axis is $b \left(\frac{h^3}{36} \right)$
- MOI about x'- axis is $b \left(\frac{h^3}{12} \right)$
- MOI about x- axis is $b \left(\frac{h^3}{3} \right)$
- MOI about x'- axis is $b \left(\frac{h^3}{36} \right)$

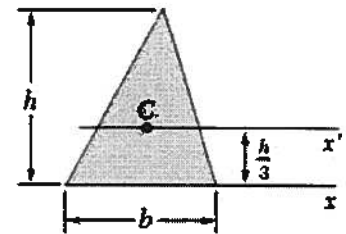

11. For a Quarter Circle placed in first quadrant with radius of "r"

- MOI about its CG is $\frac{\pi r^4}{16}$
- MOI about its Base is $\frac{\pi r^4}{16}$
- Polar MOI is half the MOI about its base
- Polar MOI is half the MOI about its CG

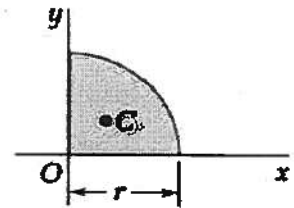

12. For a beam having two span, support at left end is hinge and remaining two are being roller, then
- Total degree of static indeterminacy is 2
 - Internal indeterminacy is 1
 - There is no internal indeterminacy and total degree of static indeterminacy is 1
 - There is no external indeterminacy and total degree of static indeterminacy is 1

13. Relation among load, shear and bending is

- Slope of shear curve is negative and absolute value of slope at any point equals to load per unit length at that point.
- Slope of shear curve is positive and absolute value of slope at any point equals to load per unit length at that point.
- Slope of bending moment curve equals to positive value of load intensity
- Slope of bending moment curve equals to negative value of load intensity

14. For 2D Warren Truss,

- Total degree of static indeterminacy is 1
- Total degree of static indeterminacy is 0
- Total degree of static indeterminacy is 2
- Total external indeterminacy is 1

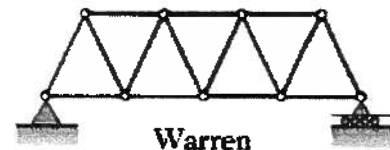

15. For the cantilever beam with point load at free end ,
- SFD and BMD are linear.
 - BMD is square parabolic.
 - SFD is linear and BMD is parabolic
 - SFD is square parabolic and BMD is cubic parabolic
16. Simply Supported beam of span "L" is carrying a UDL in whole span, then
- Shear force is maximum at the center of the beam
 - Shear force and bending moment is zero at the center of the beam
 - Bending moment is maximum at the support
 - Bending moment is maximum and shear force is zero at the middle of the beam.

17. For the dependent motion of particle as in figure,

- $x_A + 2x_B + x_C = \text{constant}$
- $2x_A + 2x_B + x_C = \text{constant}$
- $2x_A + x_B + 2x_C = \text{constant}$
- $2x_A + 2x_B + 2x_C = \text{constant}$

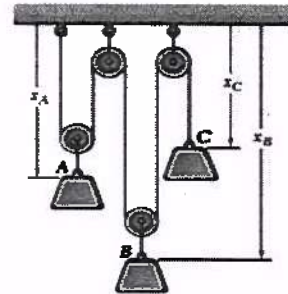

18. For a particle and rigid body, position, velocity and acceleration relation is
- For uniform rectilinear motion, velocity of a body is constant
 - For uniform accelerated rectilinear motion, velocity of a body is constant
 - A particle is said to be in rectilinear motion if it moves along a specified curve
 - Acceleration is given by multiplying velocity with rate of change of velocity with respect to time
19. Forces acting on particle and rigid body, are
- Only External forces
 - Only Internal forces
 - Only Reaction forces
 - External, Internal and Reaction forces
20. Natural time period of the single degree of freedom system depends upon
- Only mass of the system
 - Only stiffness of the system
 - Mass and stiffness of the system
 - Displacement, velocity and acceleration of the mass

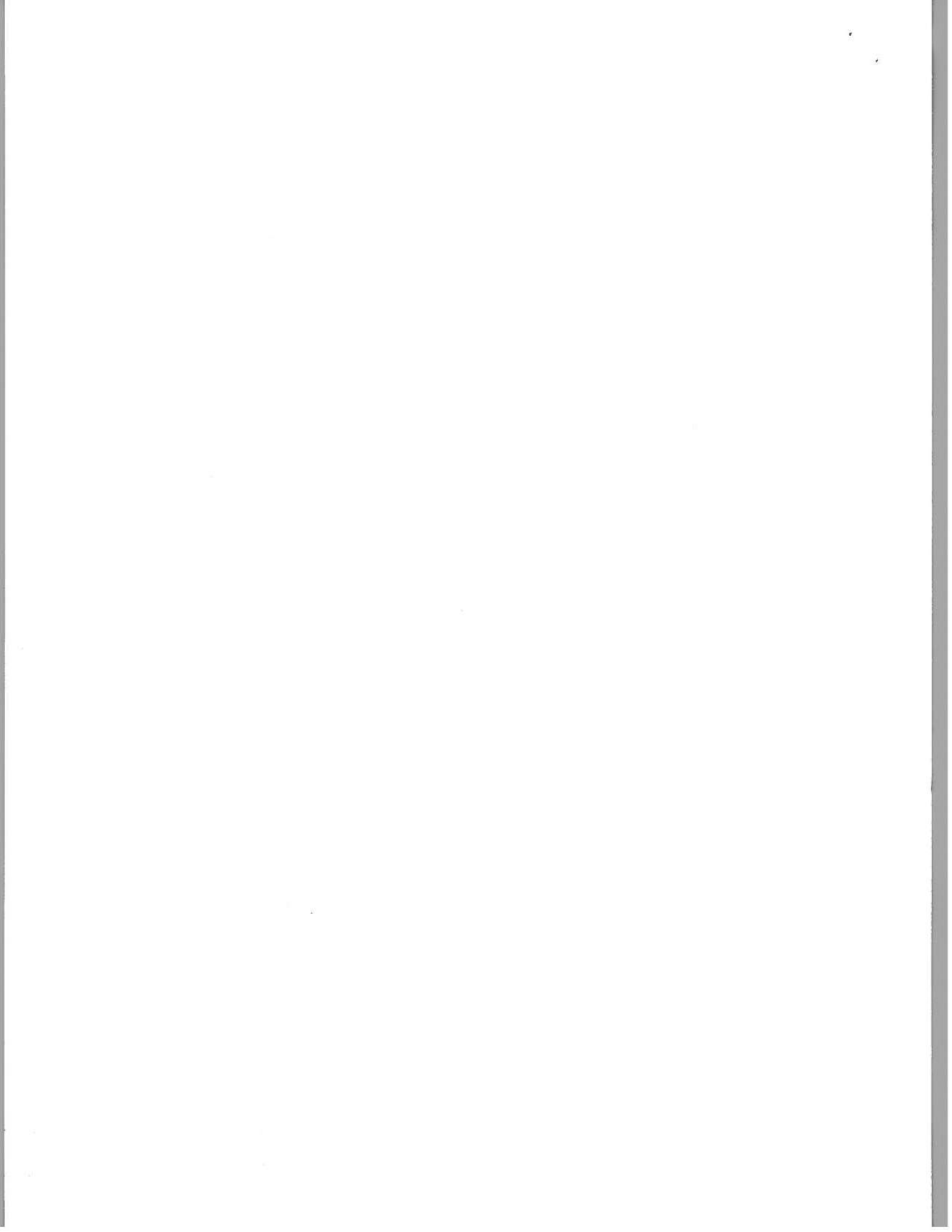

Level : B.E.
 Year : II
 Time : 2 hrs. 30 mins.

SECTION "B"

Attempt **ALL** Questions. Assume suitable data if necessary

1. For the Figure (1) (a) Determine the x and y components of each of the forces. (b) Determine the resultant (magnitude & direction) of the three forces. [2+3=5]

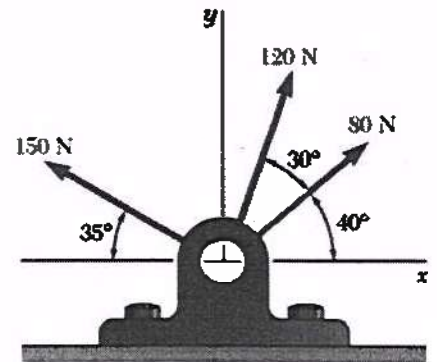

Figure 1

2. A Container of weight W Figure (2) is suspended from a ring A. Cable BAC passes through the ring is attached to fixed supports at B and C. Two forces P (in x -direction) and Q (in z -direction) are applied to the ring to make container container in the position shown. Knowing that $W = 376$ N, determine the force P and Q . (tension is the same in both portion of the cable BAC) [5]

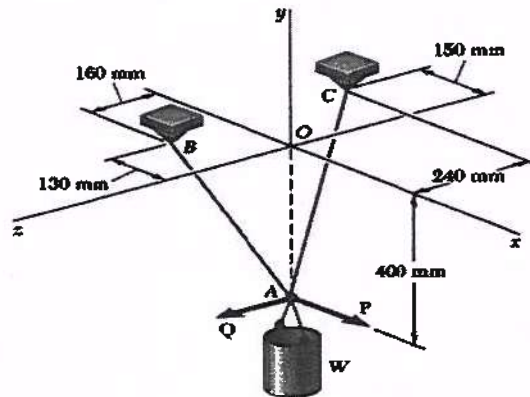
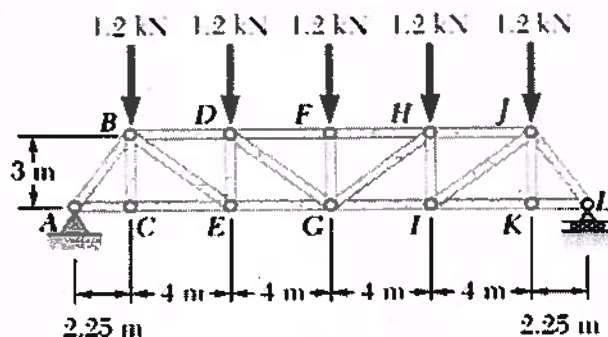
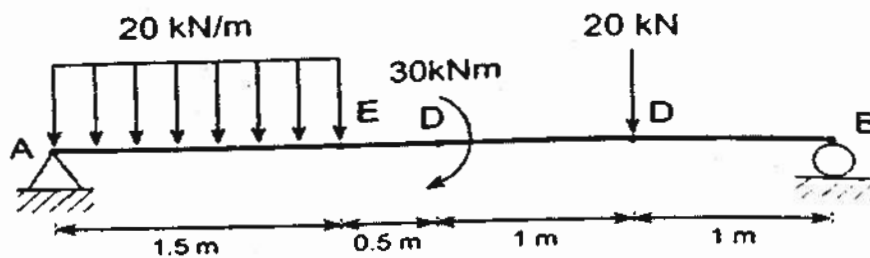

Figure 2

3. For the Given Truss, Determine the forces in the members: **DF, DG, GI & HJ**. [8]



4. Draw Shear Force Diagram (SFD) & Bending Moment Diagram (BMD) of the given beam showing important points and salient features. [4+4=8]



5. Determine by direct integration the moment of inertia of the shaded area with respect to given x-axis. [4]

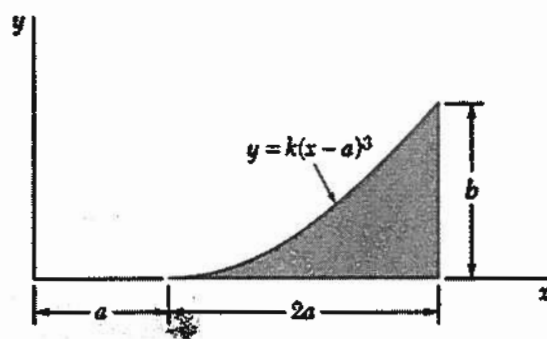

6. The two block shown starts from the rest. The horizontal plane and pulley are the frictionless, and the pulley is assumed to be of negligible mass. Determine the acceleration of each block and the tension in each block. [6]

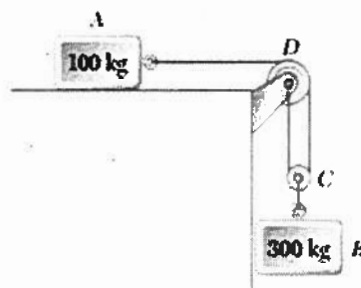

7. A ball is thrown so that the motion of is defined by the equations $x = 5t$ and $y = 2 + 6t - 4.9 t^2$, where x and y are expressed in meters and t is expressed in seconds. Determine
- Velocity at $t = 1$ sec. [2]
 - The horizontal distance the ball travels before hitting the ground. [2]

