

Marks Scored:

KATHMANDU UNIVERSITY  
End Semester Examination  
February/March, 2019

Level : B.Arch.  
Year : II

Course : ARCH 204  
Semester: I

Exam Roll No. : \_\_\_\_\_ Time: 30 mins.

F. M. : 10

Registration No.: \_\_\_\_\_

Date 05: MAR 2019

SECTION "A"  
[20 Q. × 0.5 = 10 marks]

Encircle the most appropriate answer among the given choices.

1. The maximum frictional force which comes into play when a body just begins to slide over another surface is called  
a. limiting friction    b. rolling friction    c. sliding friction    d. kinematic friction
2. Forces are called coplanar when all of them acting on body lie in  
a. one point    b. one plane    c. different planes    d. perpendicular planes
3. Which is the correct statement about law of polygon of forces?  
a. If any number of forces acting at a point can be represented by the sides of a polygon taken in order, then the forces are in equilibrium.  
b. If any number of forces acting at a point can be represented in direction and magnitude by the sides of a polygon, then the forces are in equilibrium.  
c. If a polygon representing forces acting at a point is closed then forces are in equilibrium.  
d. If any number of forces acting at a point can be represented in direction and magnitude by the sides of a polygon taken in order, then the forces are in equilibrium.
4. If a number of forces act simultaneously on a particle, it is possible  
a. to replace them by absolute force  
b. to replace them by a single force  
c. to replace them by a single force through C.G.  
d. to replace them by a couple
5. The algebraic sum of the resolved parts of a number of forces in a given direction is equal to the resolved part of their resultant in the same direction. This is as per the principle of  
a. forces    b. independence of forces  
c. resolution of forces    d. balance of force
6. According to principle of transmissibility of forces, the effect of a force upon a body is  
a. maximum when it acts at the center of gravity of a body  
b. different at different points in its line of action  
c. the same at every point in its line of action  
d. minimum when it acts at the C.G. of the body
7. According to law of triangle of forces  
a. three forces acting at a point will be in equilibrium  
b. three forces acting at a point can be represented by a triangle, each side being proportional to force  
c. if three forces acting upon a particle are represented in magnitude and direction by the sides of a triangle, taken in order, they will be in equilibrium  
d. if three forces acting at a point are in equilibrium, each force is proportional to the sine of the angle between the other two.



Level : B.Arch.  
Year : II  
Time : 2 hrs. 30 mins.

Course : ARCH 204  
Semester: I  
F. M. : 40

SECTION "B"

Attempt ALL questions. Assume data if necessary.

1. For the plane area shown in Figure 1, determine: [8]  
i. The first moments with respect to  $x$  and  $y$  axes.  
ii. The location of the centroid.

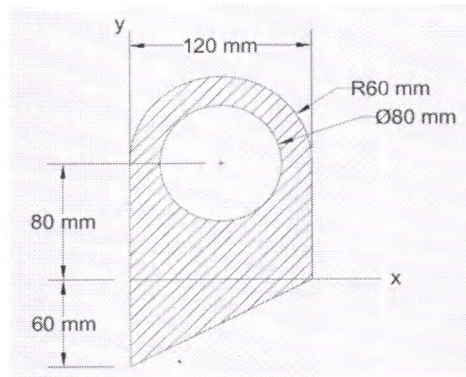

Figure 1

2. Determine the force in members marked with of the truss shown in Figure 2. Show the values of forces on a clear diagram and state the nature of forces in each member. [8]

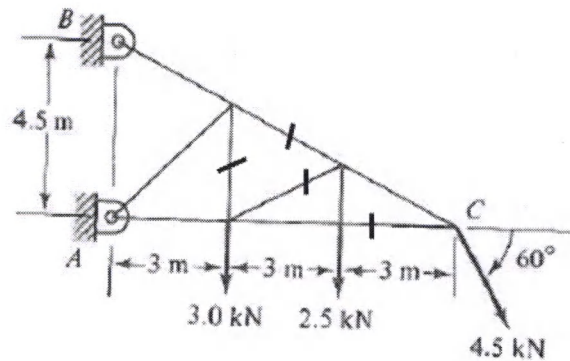

Figure 2

3. Draw the shear and bending moment diagrams with their values at significant points for the beam and loading shown in Figure 3. What are the maximum values of shear force and bending moment and their locations? [10]

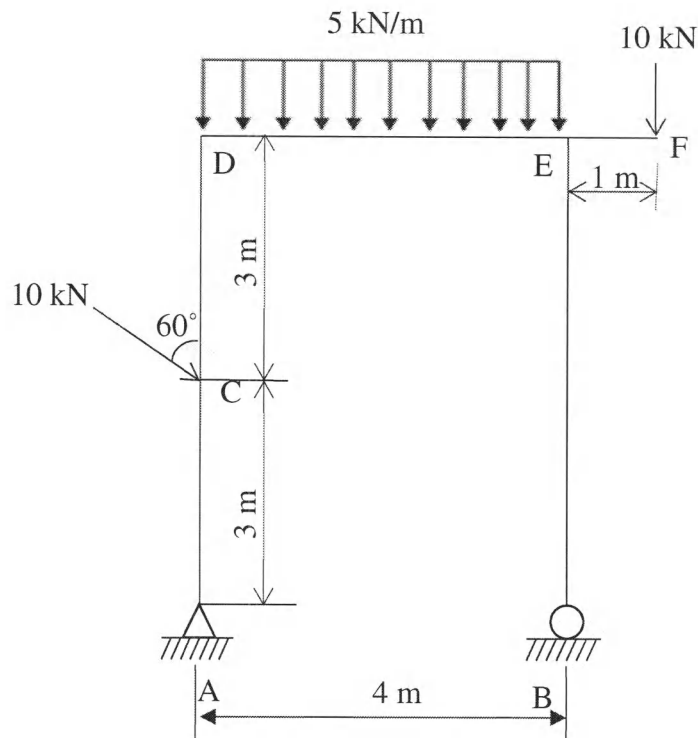

Figure 3

4. Find the magnitude, direction and position of resultant force of the following system as shown in Figure 4. (The rectangle is 5 m  $\times$  3 m) [8]

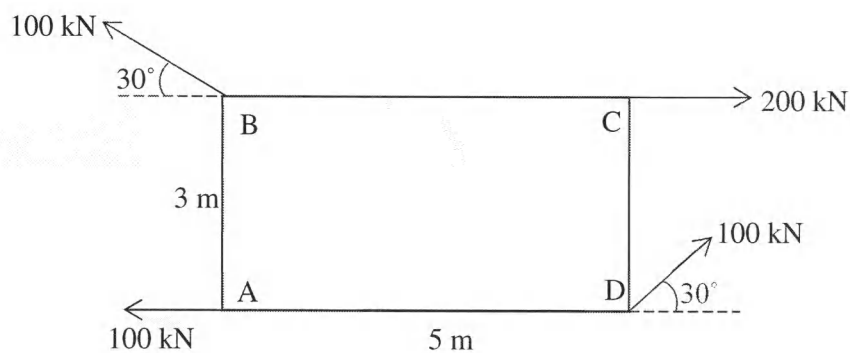

Figure 4

5. Determine the force required for impending motion of the block B shown in Figure 5. Take  $\mu_s = 0.3$  for all surfaces. [6]

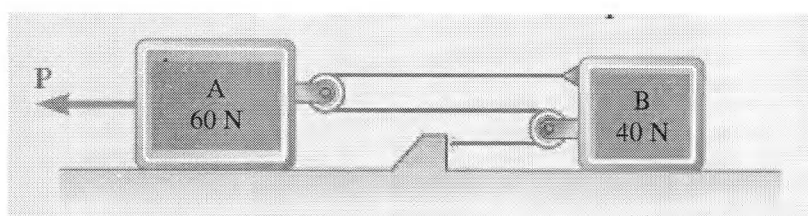

Figure 5